

Hani Buri, scientist, architect epfl fas  
Folded plate geometries for timber constructions

Chapel for the deaconesses of St Loup

Shel

Hani Buri, Yves Weinand  
Architecture, Engineering and Production Design

# IBOIS laboratory for timber constructions



## Direction

Prof. Yves Weinand, ISA architect, EPFL civil engineer,  
Associated Professor

## Administration

Hildegard Bachmann, secretary

## Staff

Hani Buri, EPFL architect, scientific collaborator

Johannes Natterer, EPFL SIA civil engineer, PhD assistant

Ivo Stotz, EPFL architect, PhD assistant

Gilles Gouaty, DEA EDIIS Lyon (F) computer scientist, PhD assistant

Markus Hudert, Städelschule Frankfurt (D) architect, PhD assistant

François Demoures, EPFL mathematician, PhD assistant



## Research at IBOIS

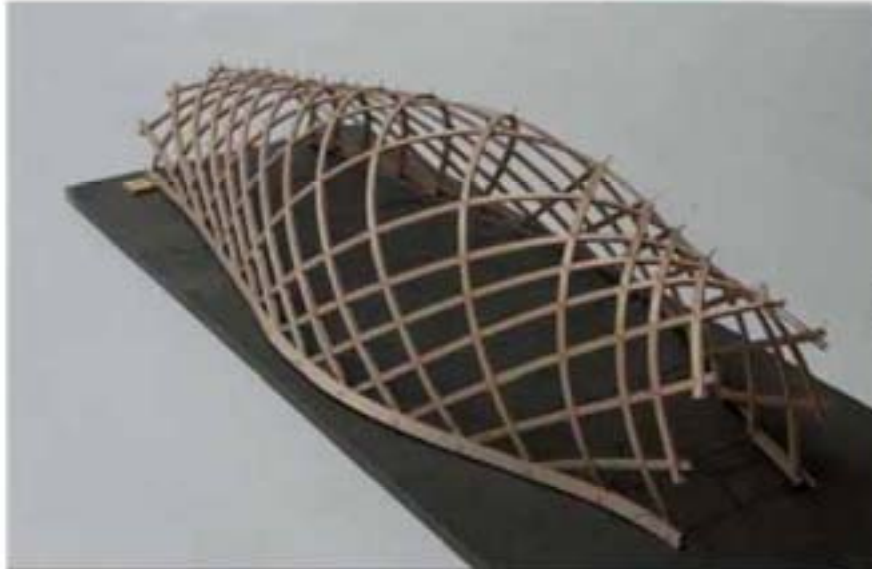

## Free form shell structures

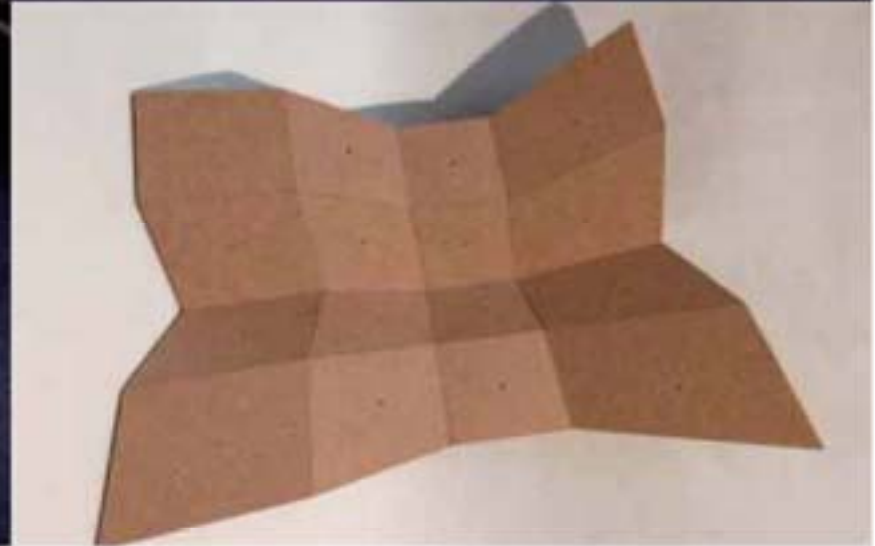
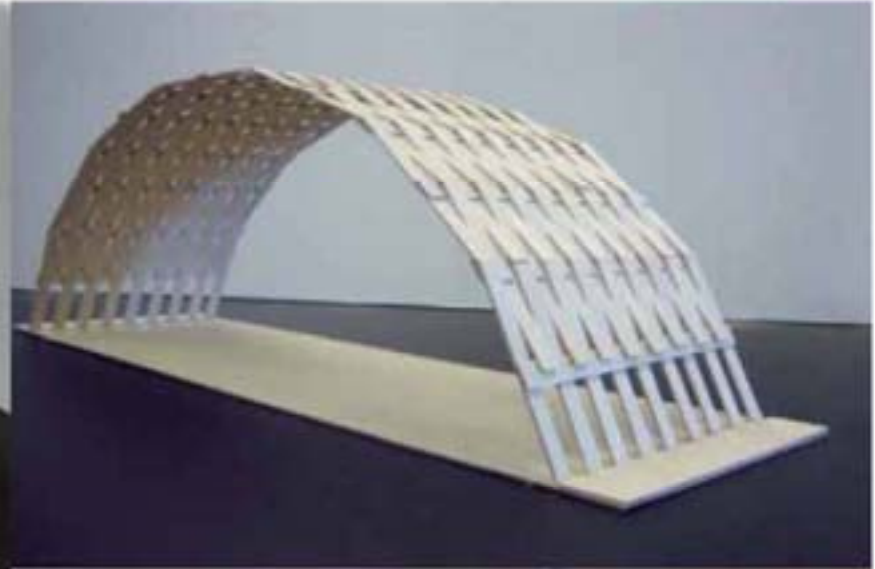

# Origami – Folded Plate structures

An interdisciplinary research between architects, engineers and mathematicians

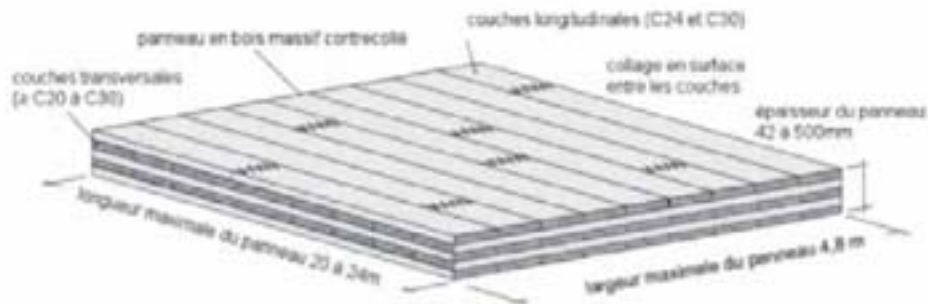
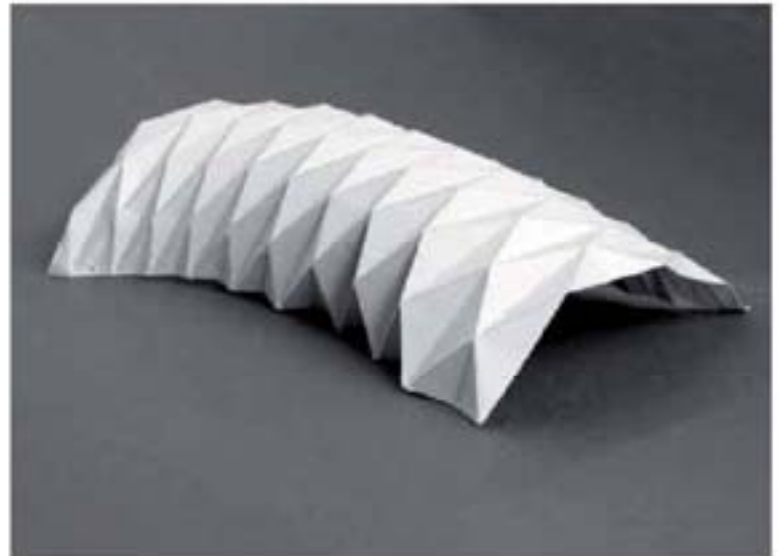
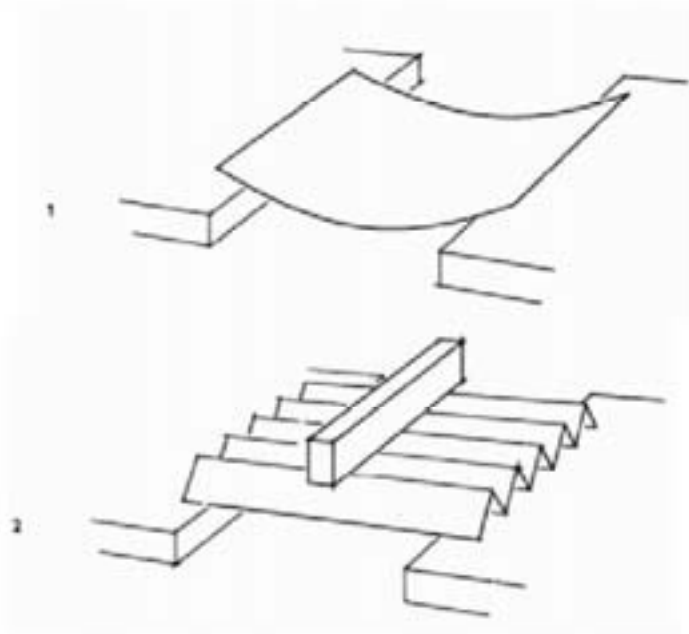

## Paper folding



## Geometric analysis



## Prototypes



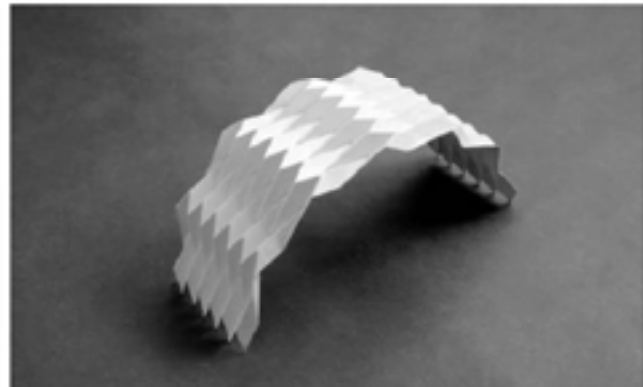
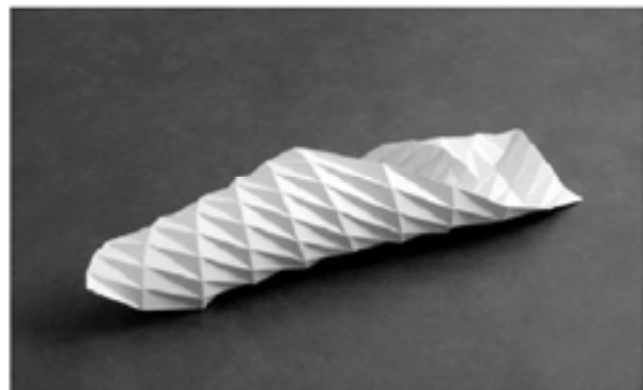
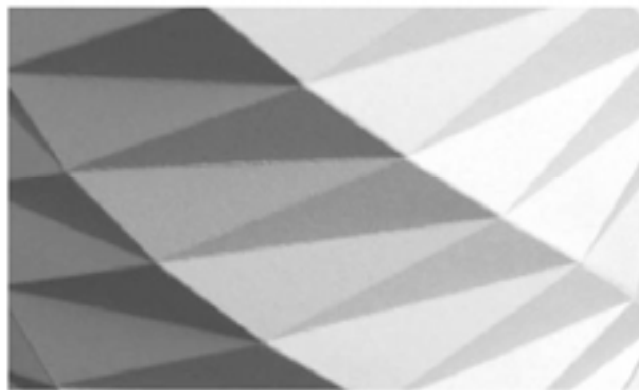
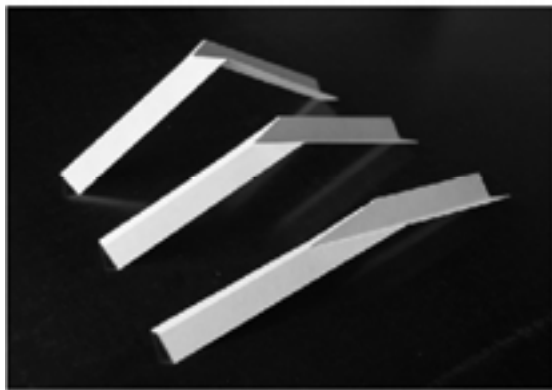
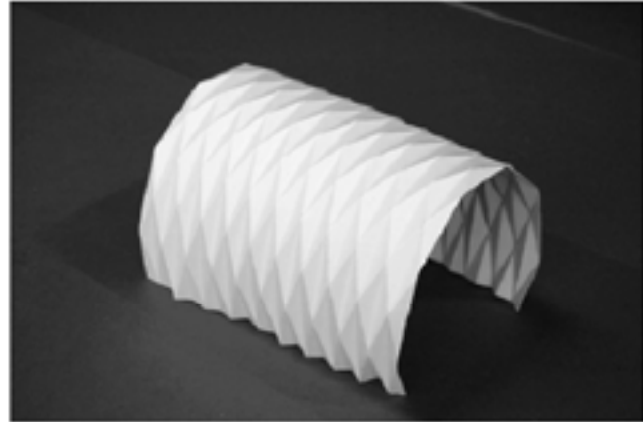
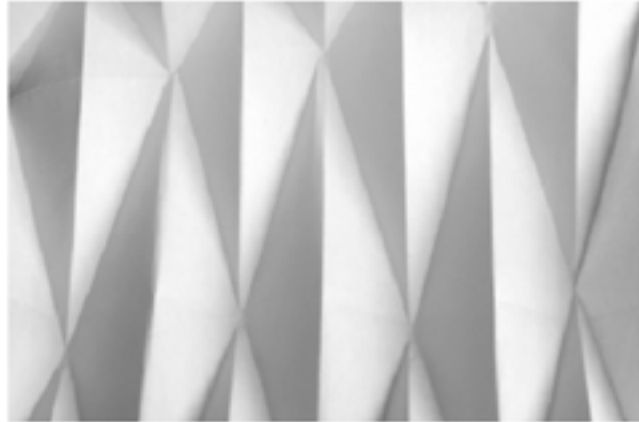

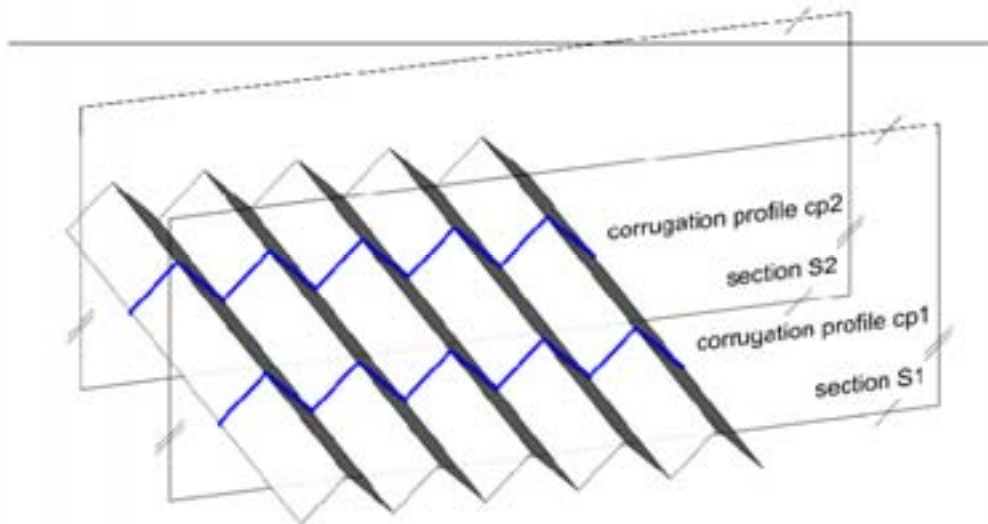

Parallel folds

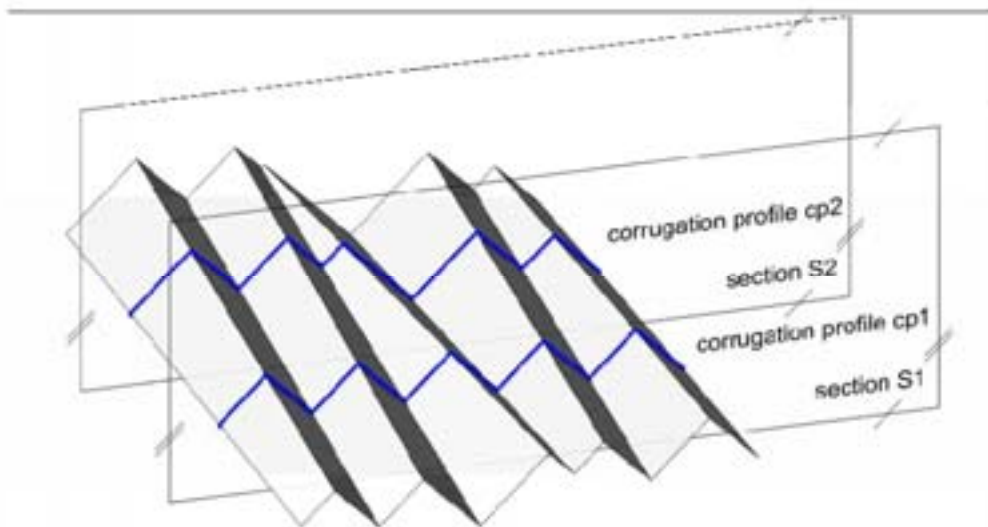

Non Parallel folds

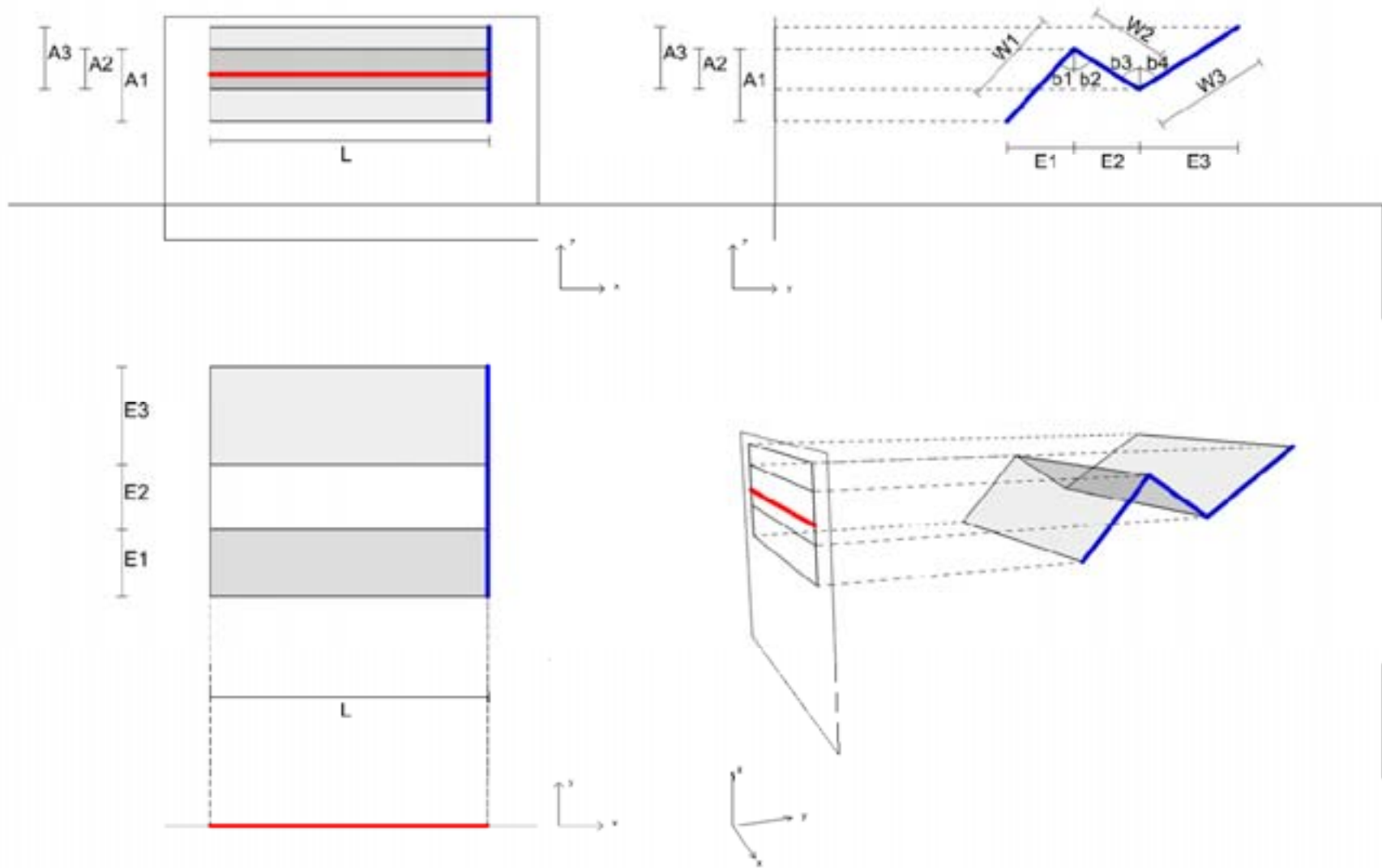

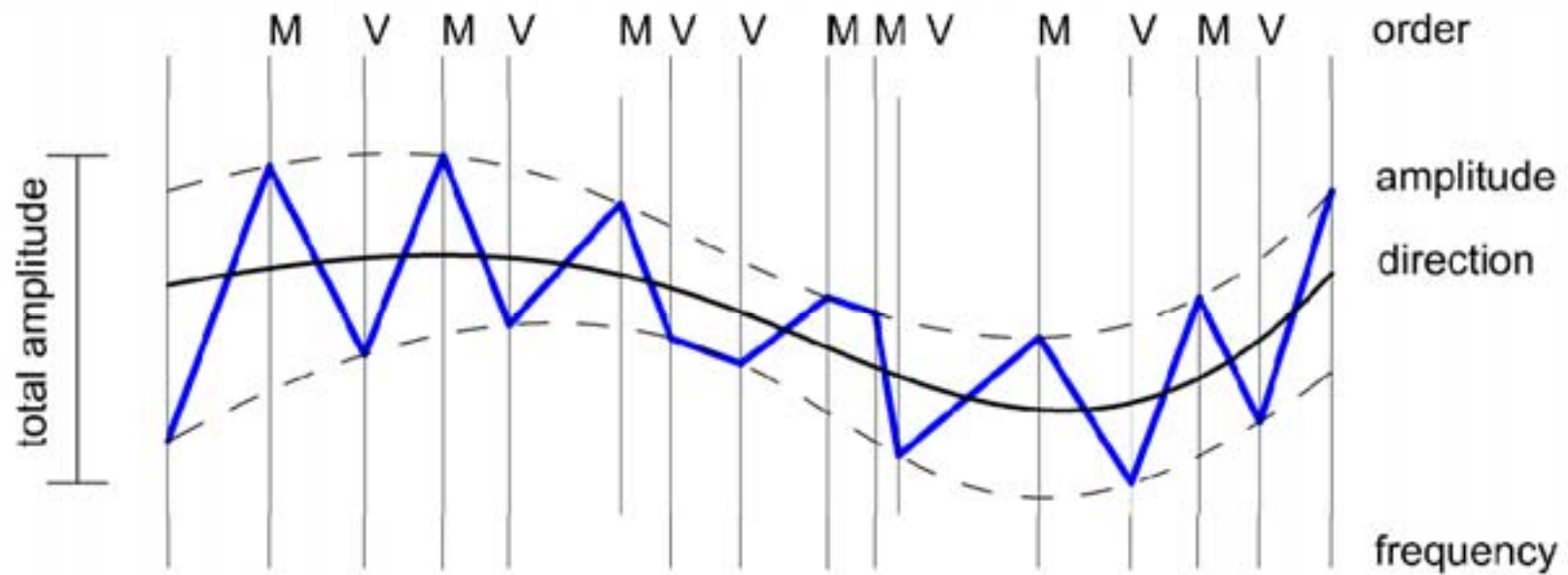

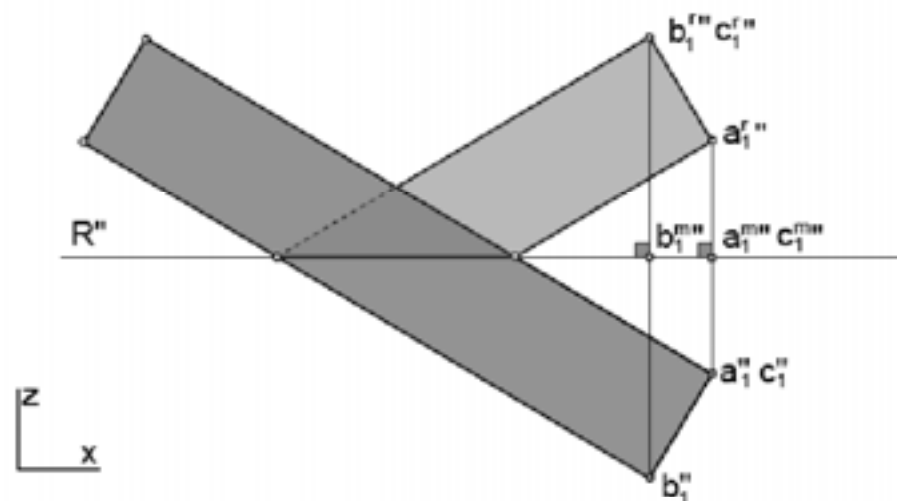
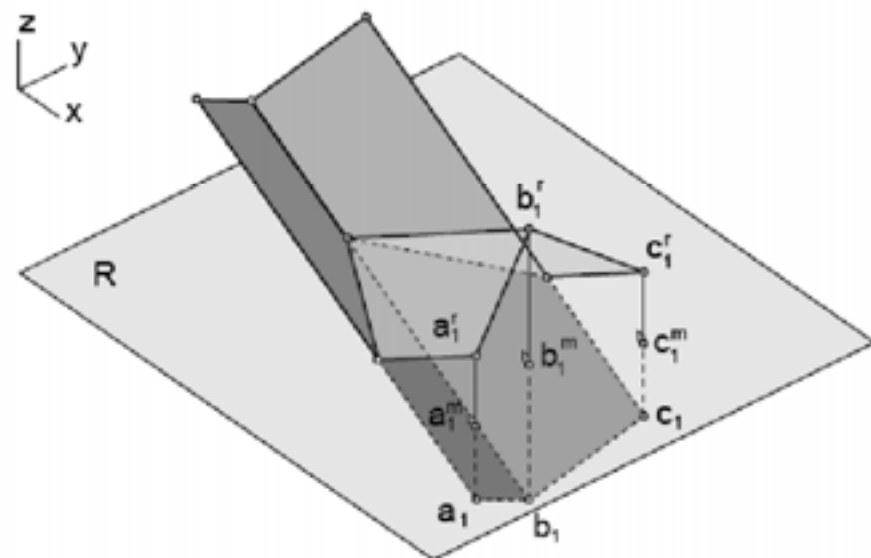
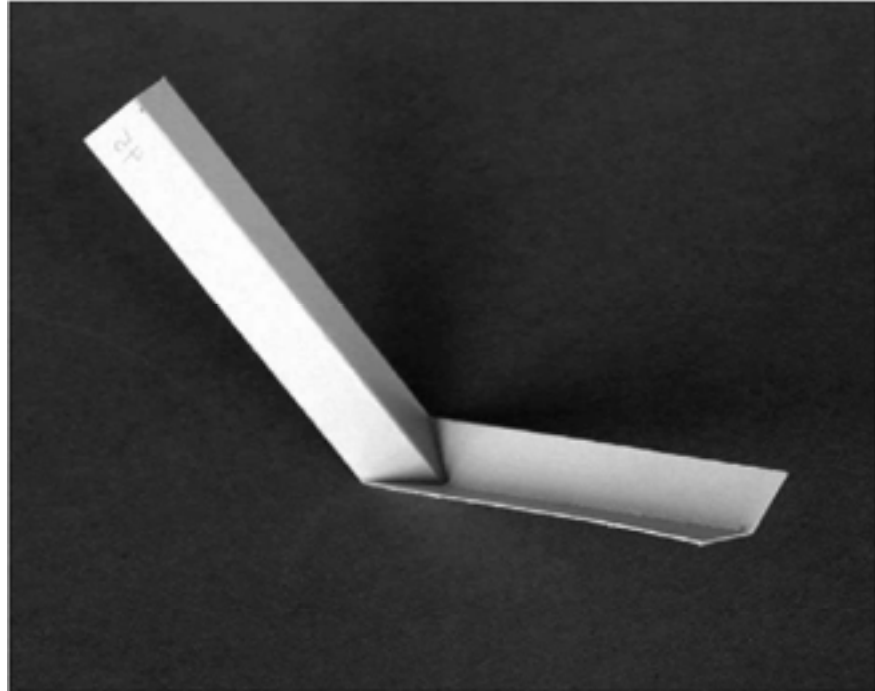

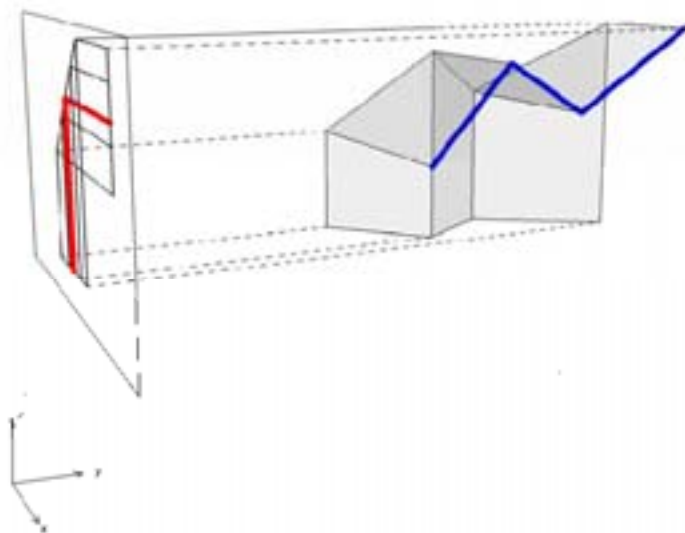
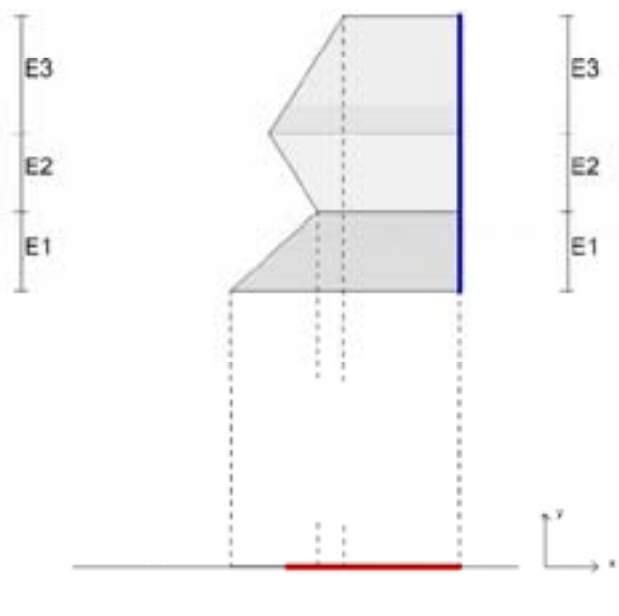
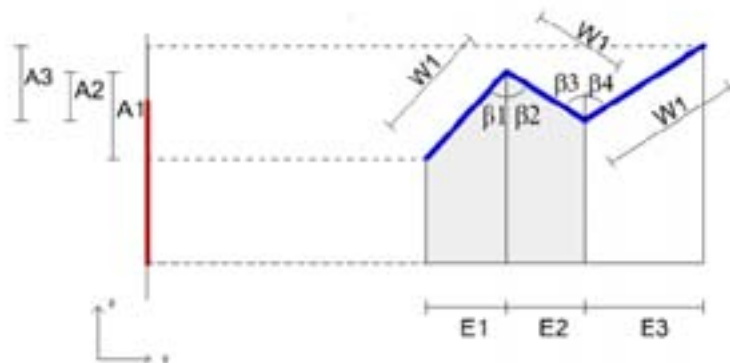
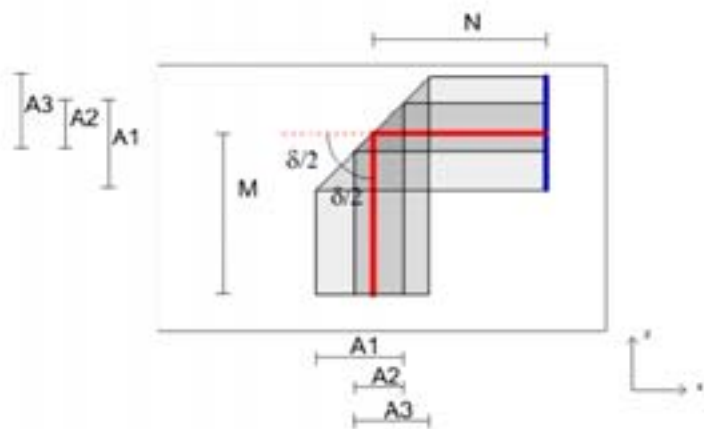

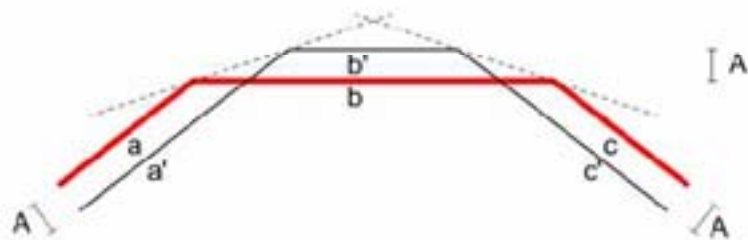
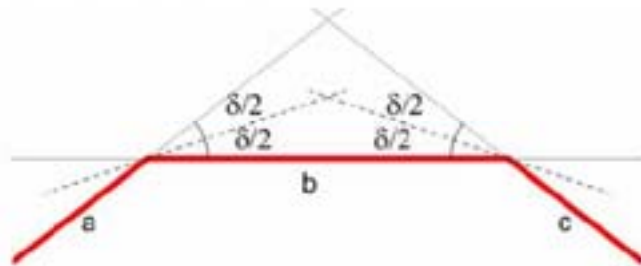
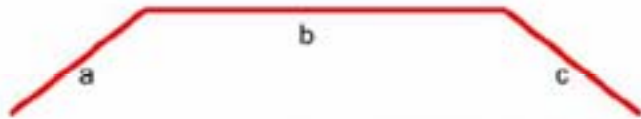

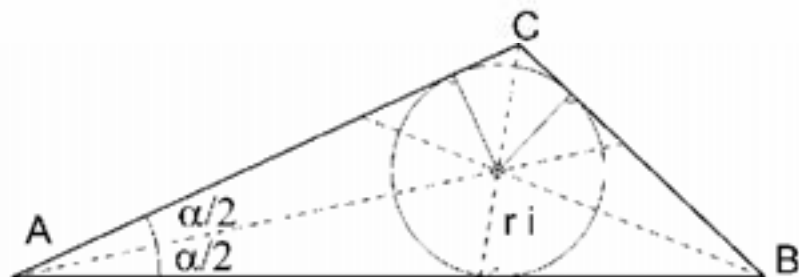
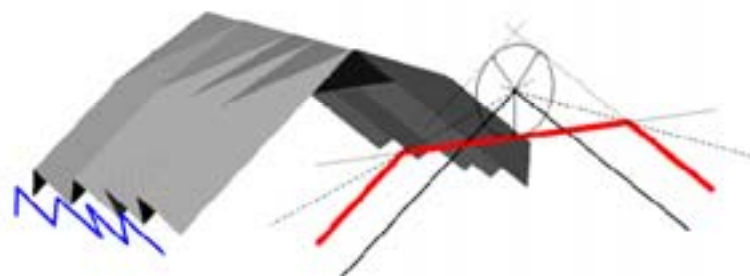
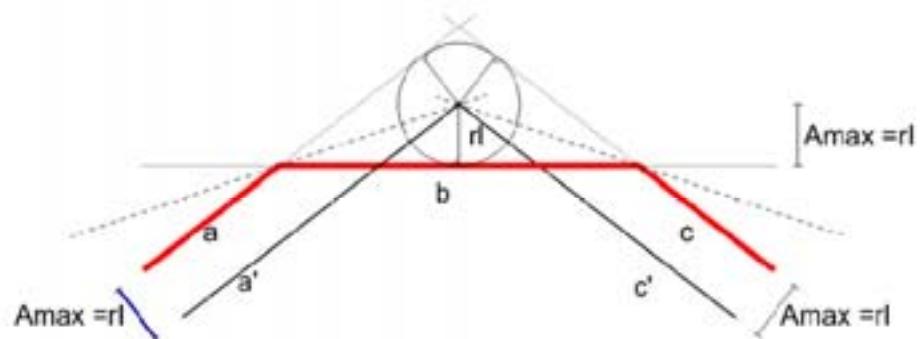
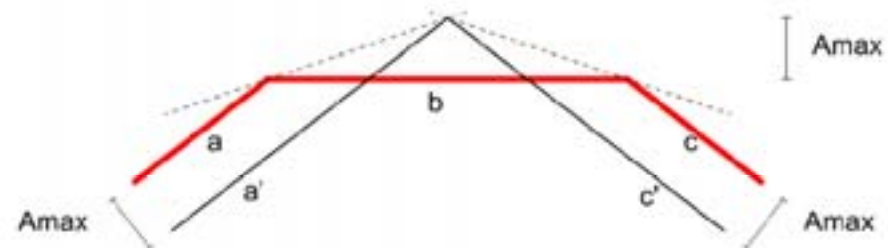

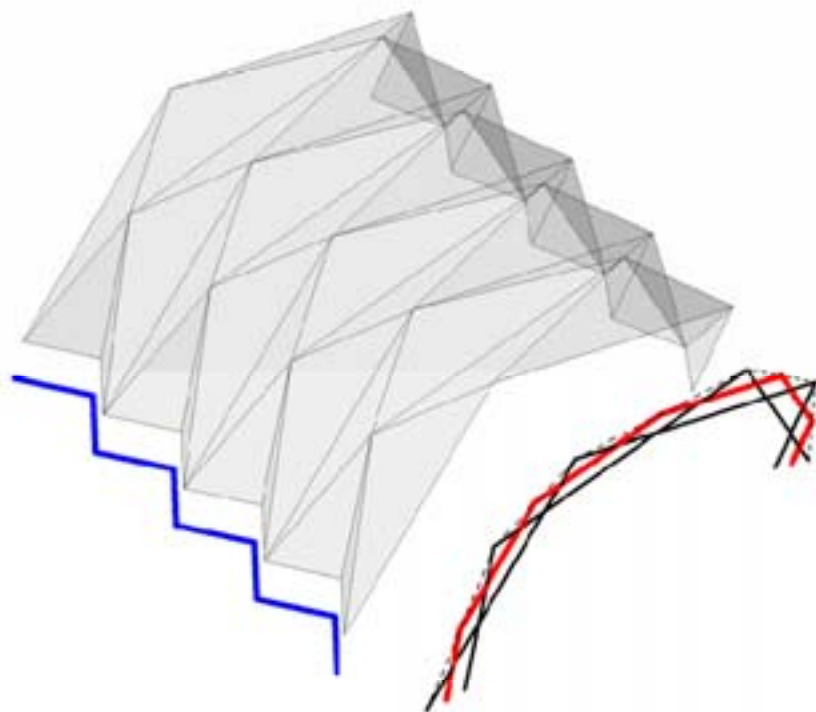
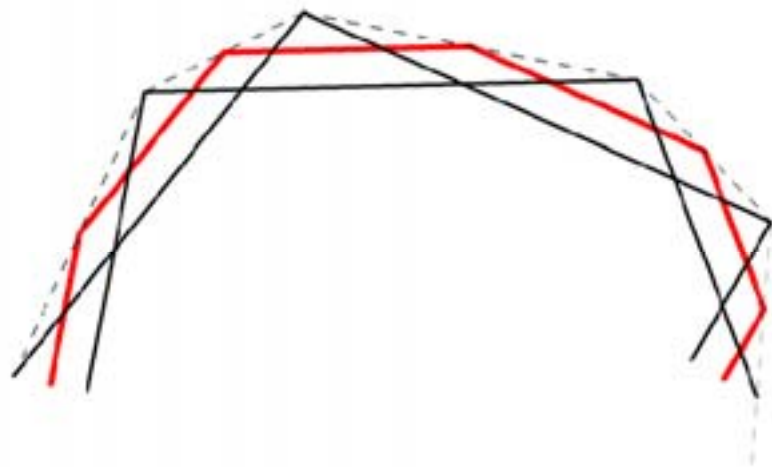
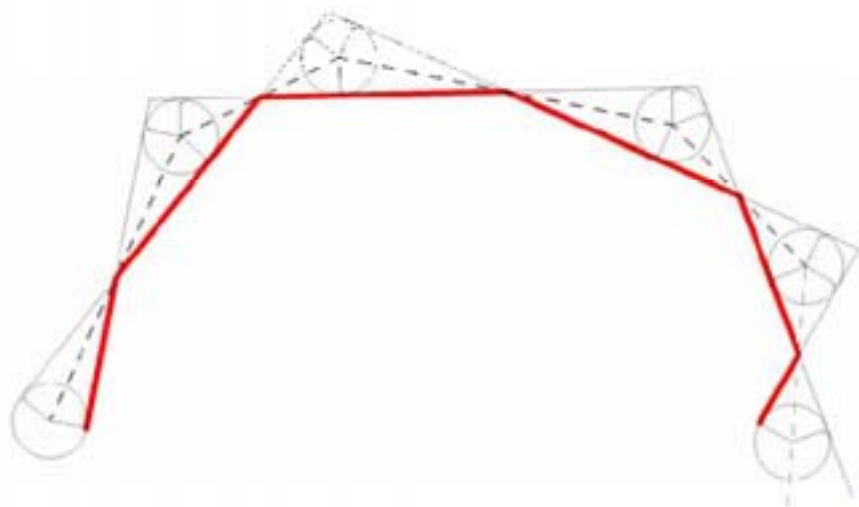

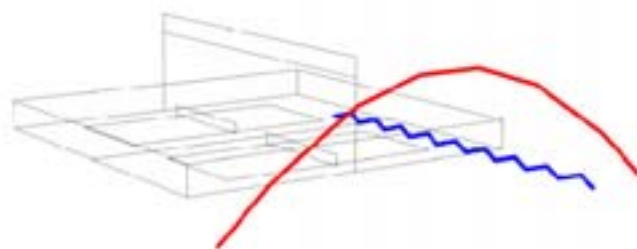
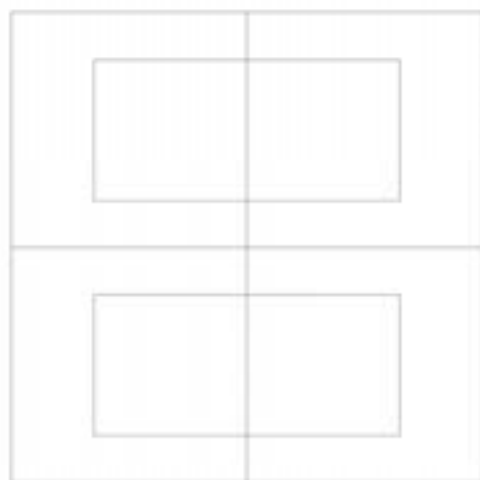

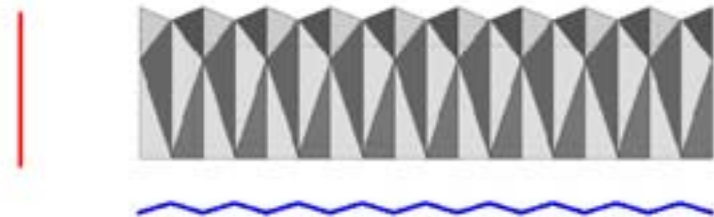
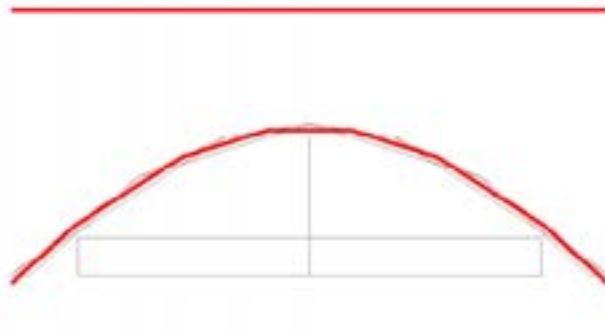
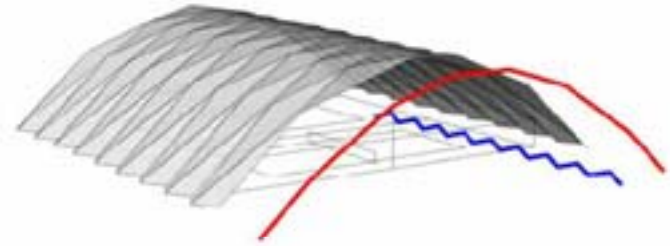
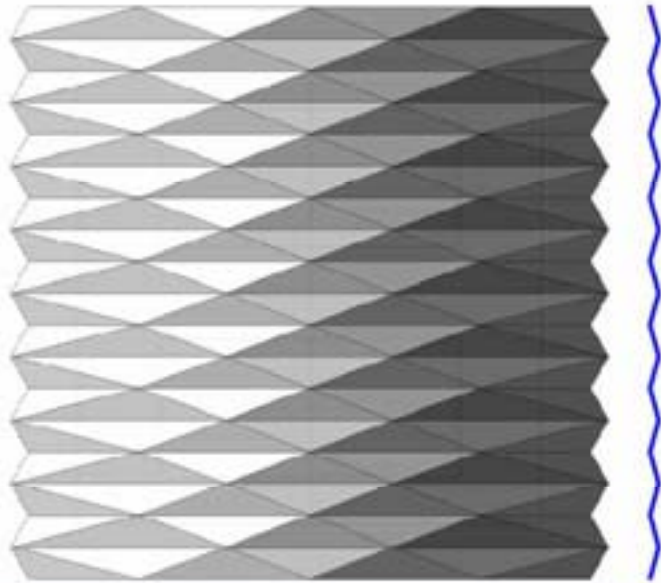

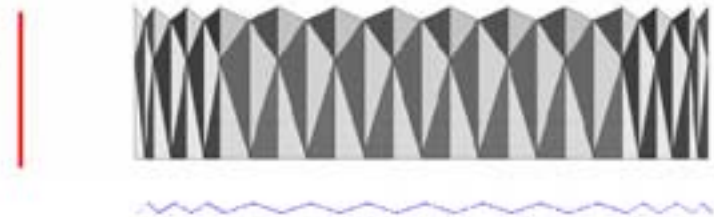
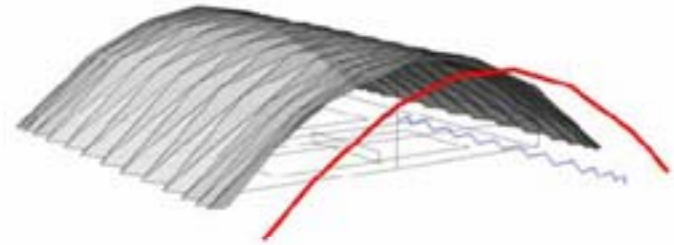
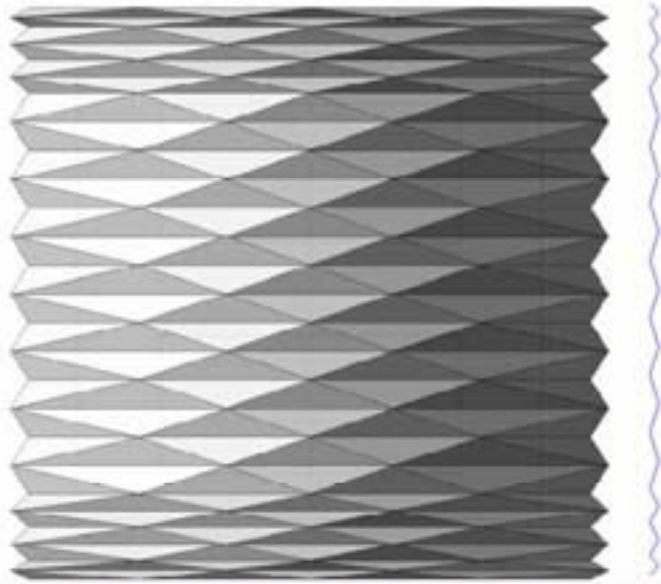

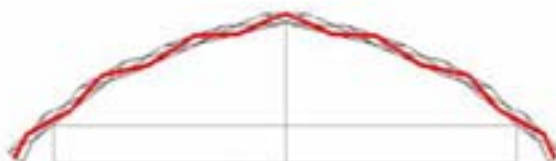
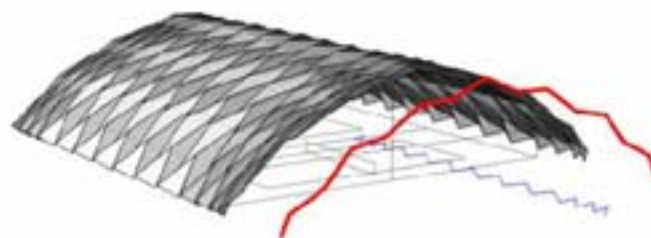
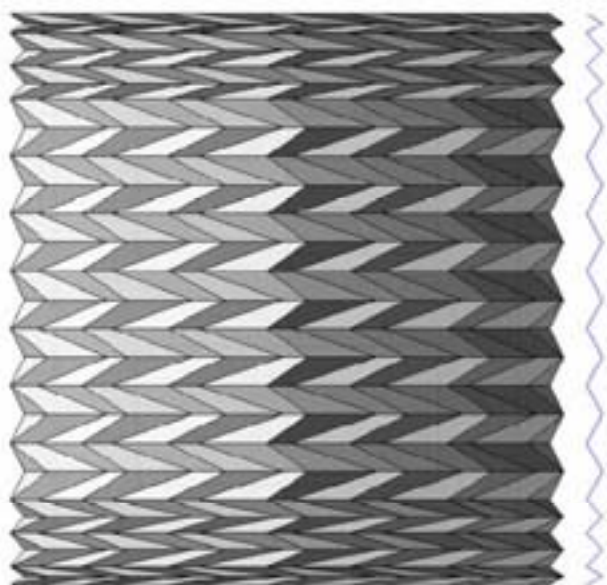

# Digital modeling

single patch geometries

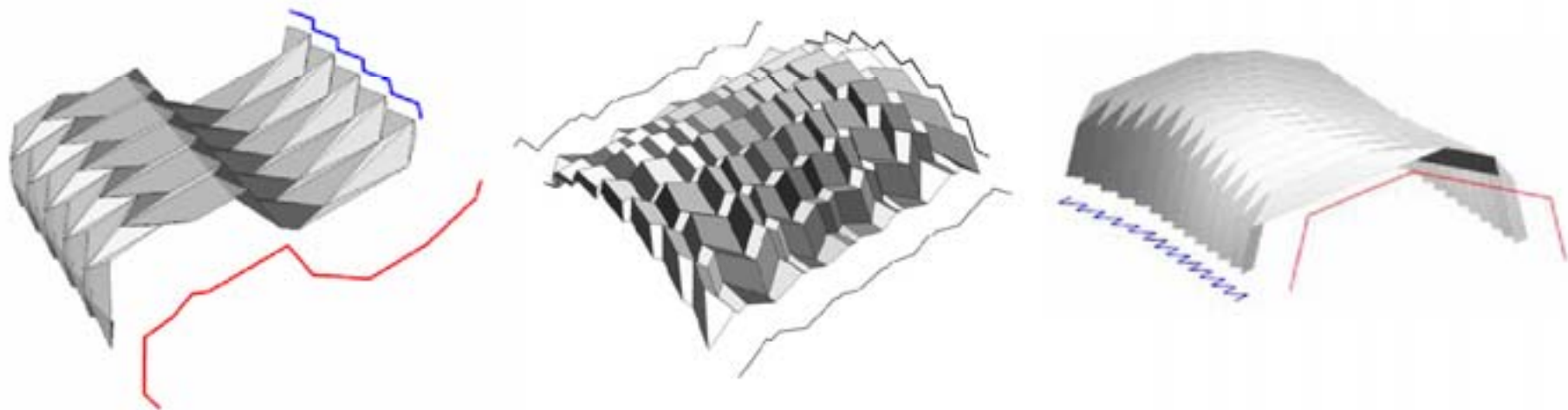

multi patch geometries

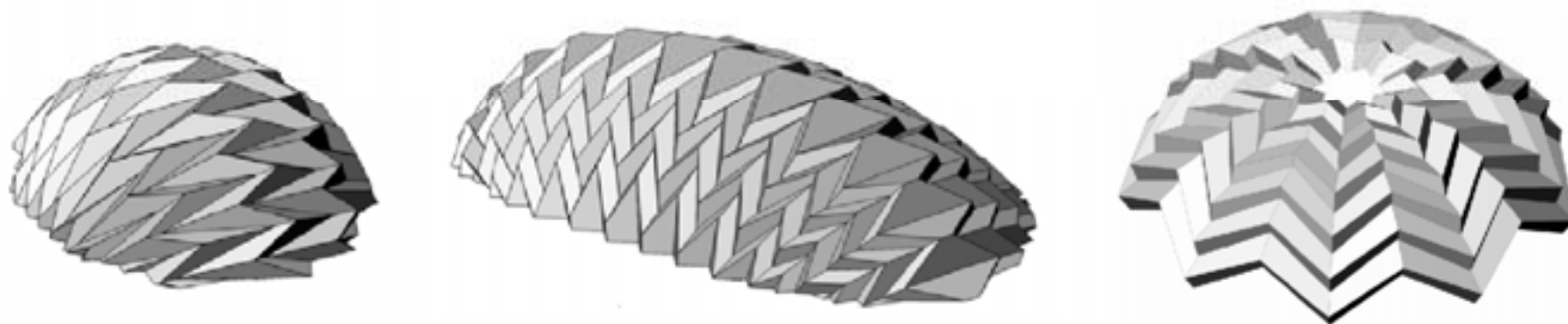

## Prototype



Hani Buri, Marcel Haasis, François Demoures



iBOIS

*Folded plate geometries for timber constructions*  
Hani Buri  
Tallin, november 2006

# engineering

Both numerical simulation and laboratory testing contribute important information

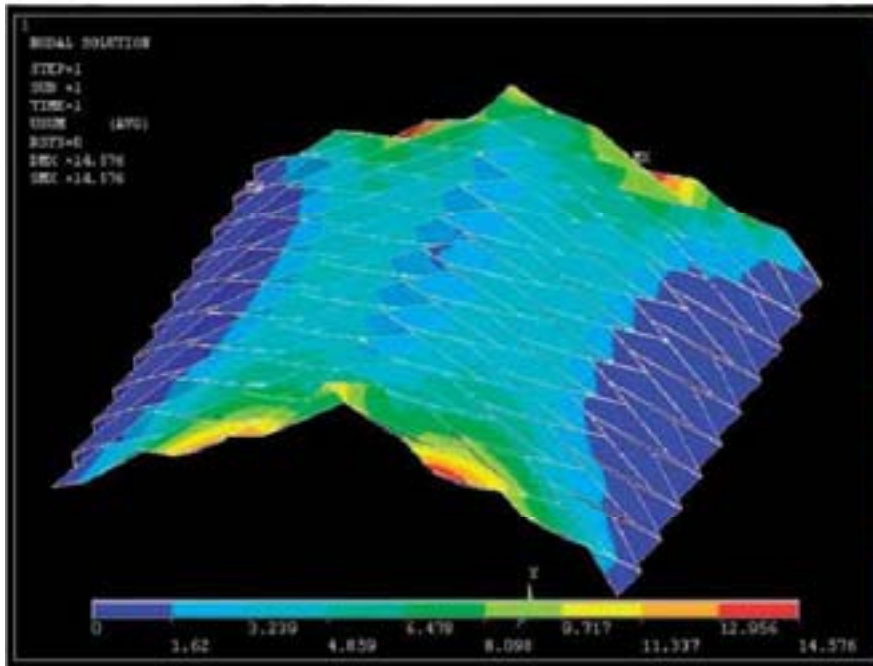

Hani Buri, Marcel Haasis, François Demoures

## Variations of amplitude and extension of a folded plate structure:

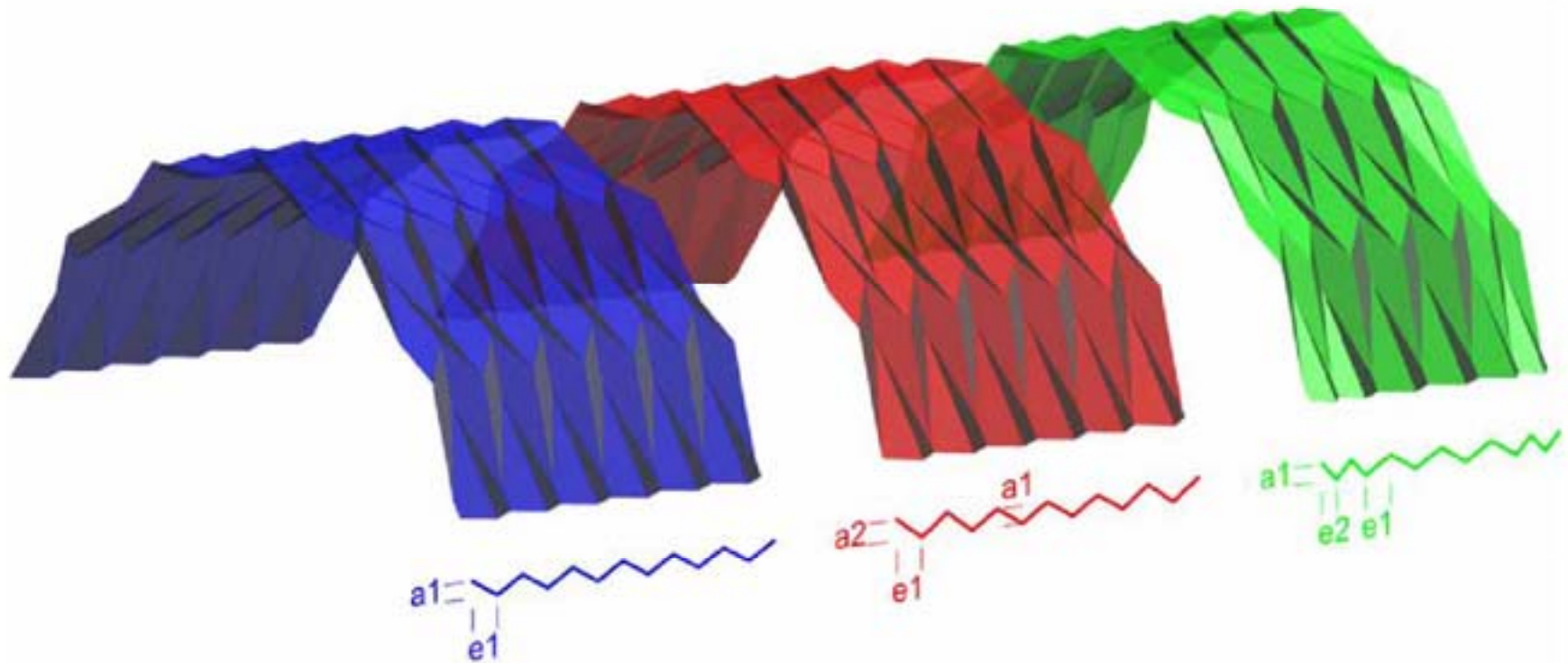

1. amplitude  $a_1$  constant  
extension  $e_1$  constant

2. amplitude  $a_2 > a_1$   
extension  $e_1$  constant

3. amplitude  $a_1$  constant  
extension  $e_2 < e_1$

## Internal forces

## Deformations

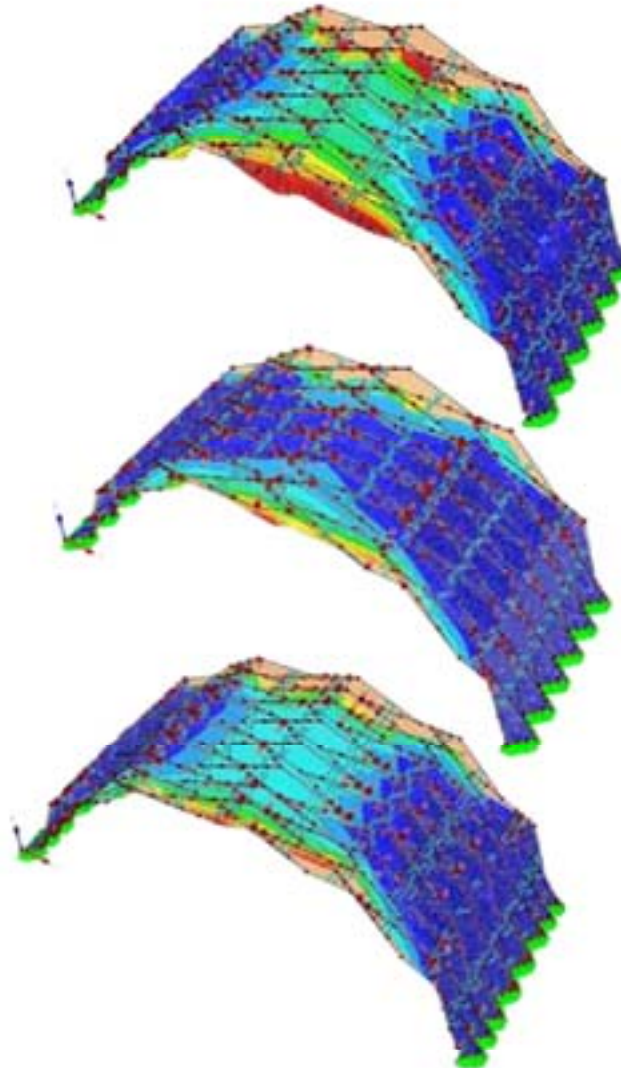
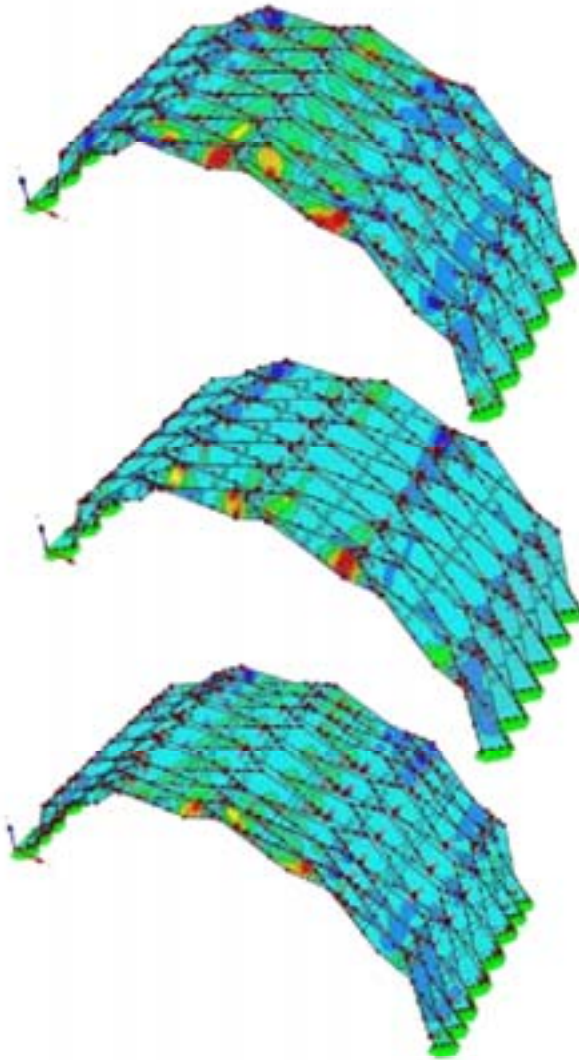

1. Max vectorial displacement 3.3 mm

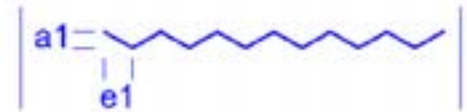

2. Max vectorial displacement 2.2 mm

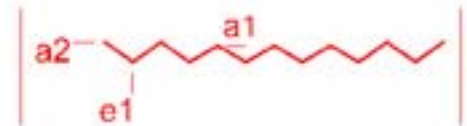

3. Max vectorial displacement 1.9 mm

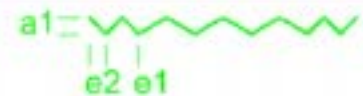

# A temporary chapel for the deaconesses of St.Loup

## CLIENT

Institution des Diaconesses de St.Loup

## PROJECT AUTHORS

Groupement d'architectes

Localarchitecture

Bureau d'architecture Danilo Mondada

Shel

Hani Buri, Yves Weinand

Architecture, Engineering and Production Design

a IBOIS EPFL start up

## GOVERNMENT GRANT

Federal Office for the Environment FOEN



**Shel**

*Hani Buri, Yves Weinand*  
Architecture, Engineering and Production Design

*Chapel for the deaconesses of St Loup*

*Hani Buri*

*Tallin, november 2006*

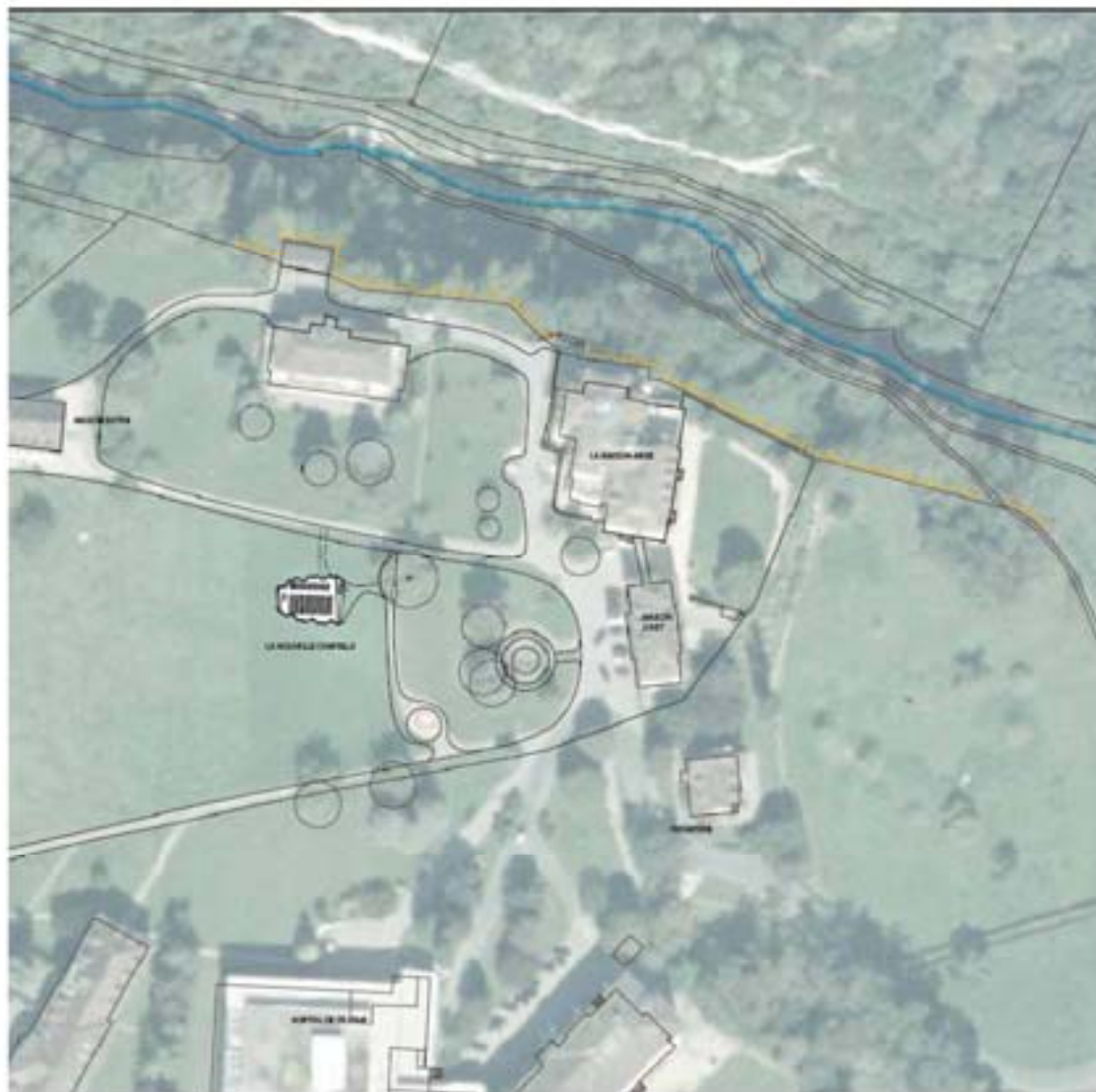

Situation



1



2



3

1 Kapelle Betlis, Amden (<http://www.amden.ch/de/navpage-HikeHL-gwanderungenAW-80991.html> )

2 Nepomuk-Kapelle, Holzem (<http://www.villip.de> )

3 Kapelle Sogn Benedetg, Architekt PZumthor, Aussenansicht (<http://www.flickr.com/photos/306/2088363809/>)

Shel

*Hani Buri, Yves Weinand*  
Architecture, Engineering and Production Design

*Chapel for the deaconesses of St Loup*  
Hani Buri *Tallin, november 2006*

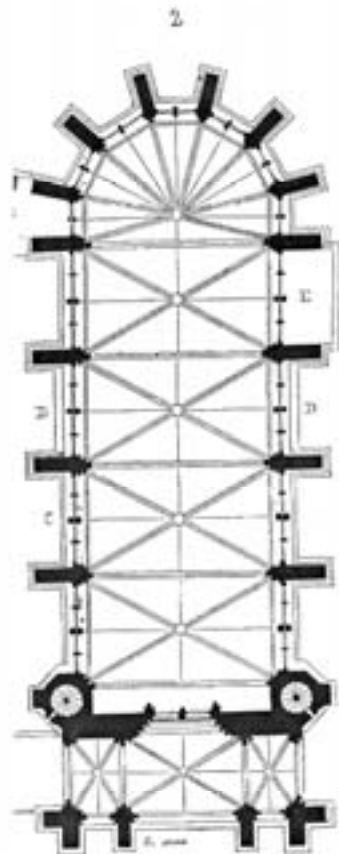

1



2



3

1 Sainte chapelle, Paris, Plan chapelle haute (dictionnaire raisonné d'architecture E.Viollet-le-Duc)

2 Sainte chapelle, Paris, Innenansicht (<http://www.flickr.com/photos/22646437@N04/2557968416/>)

3 Kapelle Sogn Benedetg, architecte PZumthor, Innenansicht(<http://www.flickr.com/photos/p2cl/354240964/>)

Shel

Hani Buri, Yves Weinand  
Architecture, Engineering and Production Design

*Chapel for the deaconesses of St Loup*  
Hani Buri                      Tallin, november 2006

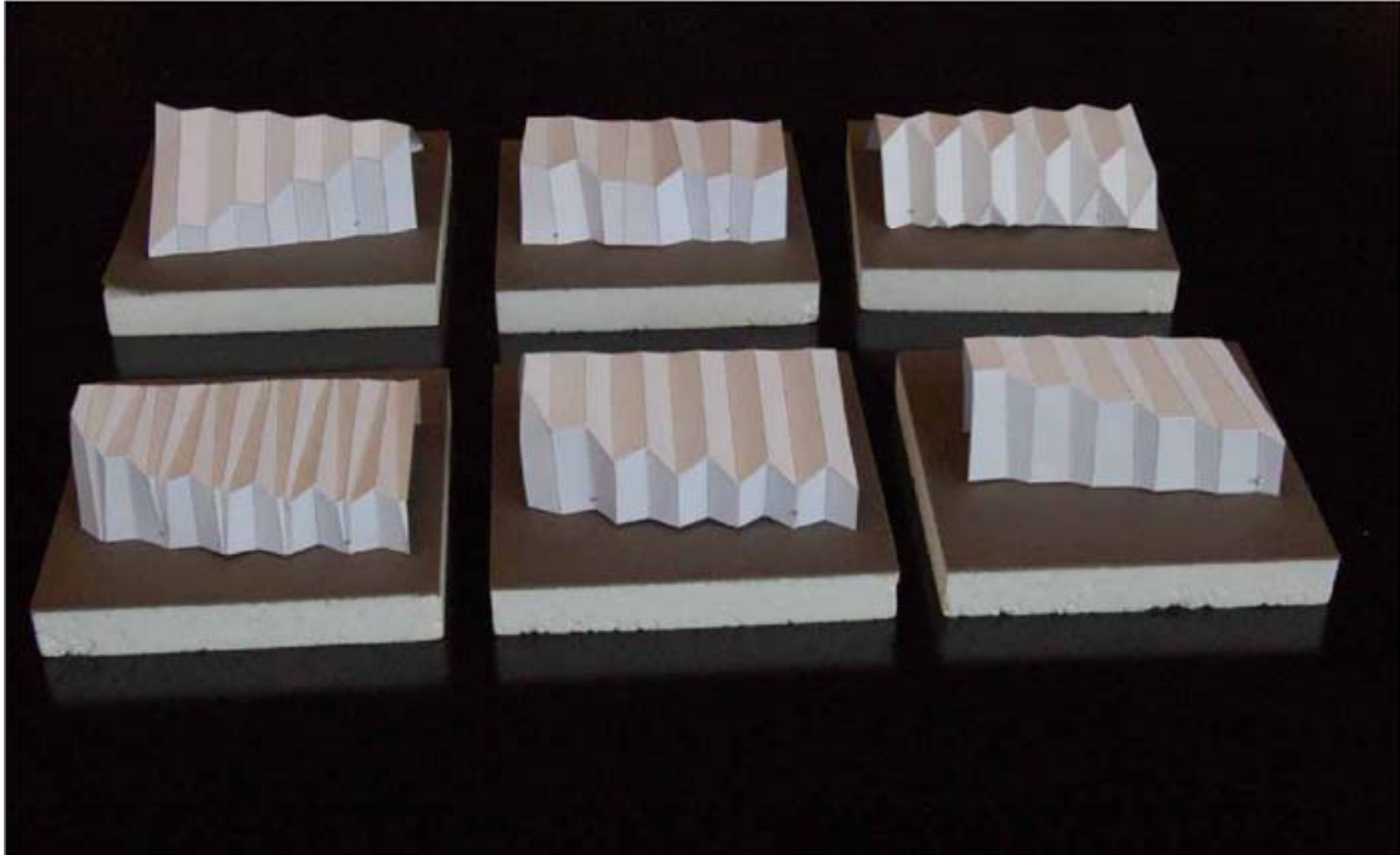

Shel

*Hani Buri, Yves Weinand*  
Architecture, Engineering and Production Design

*Chapel for the deaconesses of St Loup*  
*Hani Buri* *Tallin, november 2006*

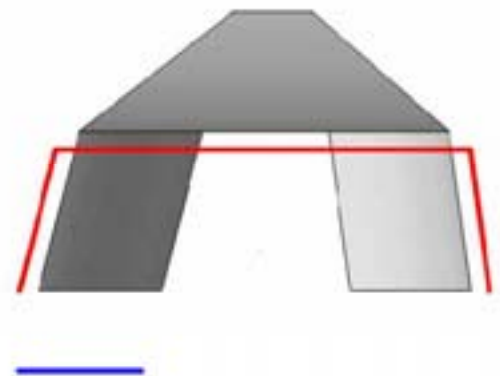
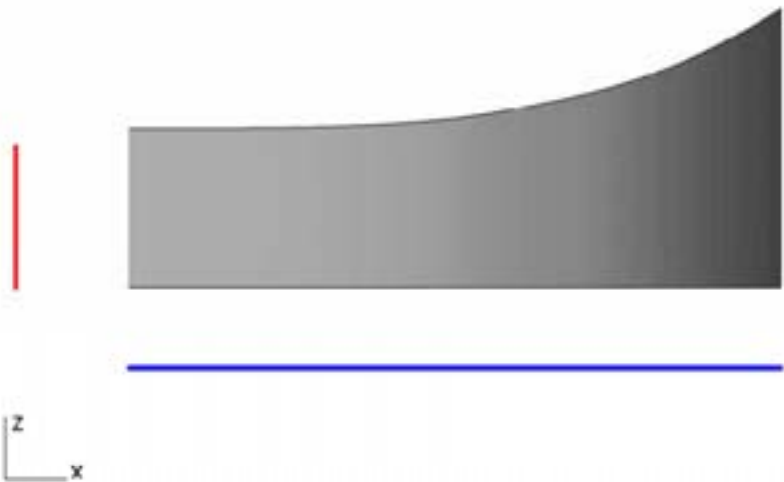
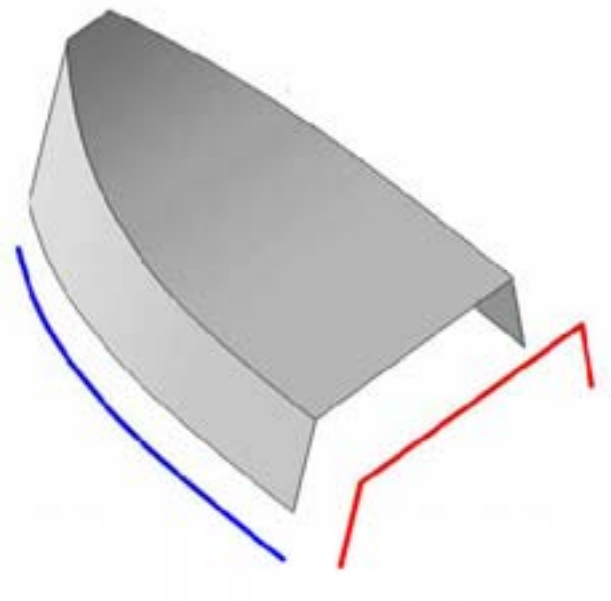
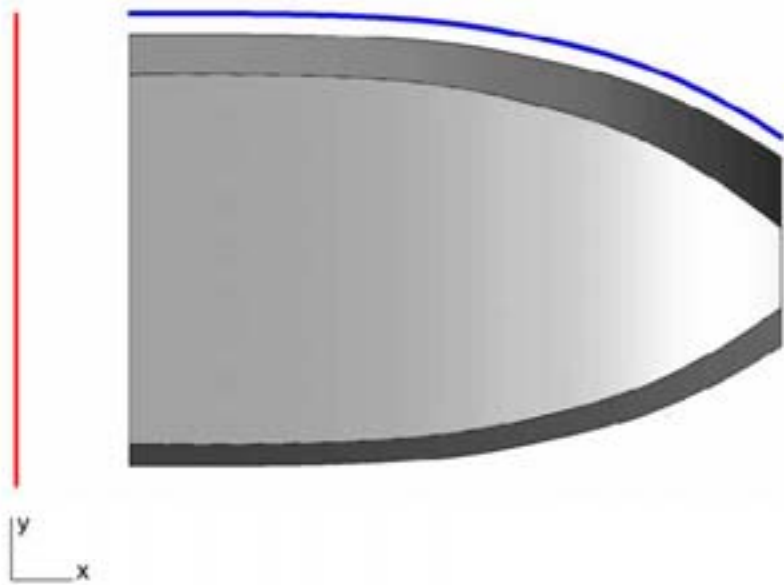

**Shel**

*Hani Buri, Yves Weinand*  
 Architecture, Engineering and Production Design

**Chapel for the deaconesses of St Loup**  
*Hani Buri* *Tallin, november 2006*

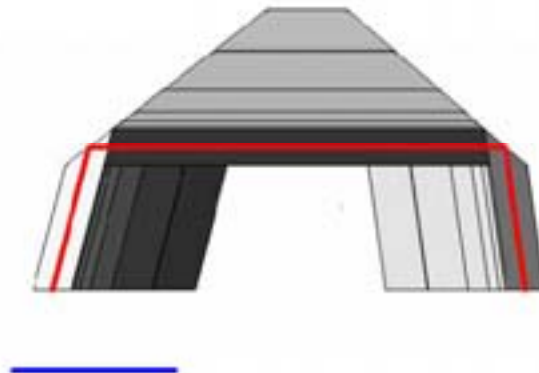
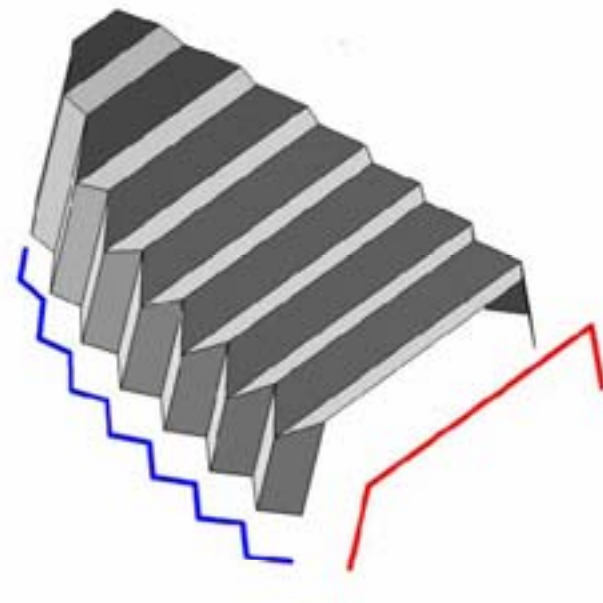
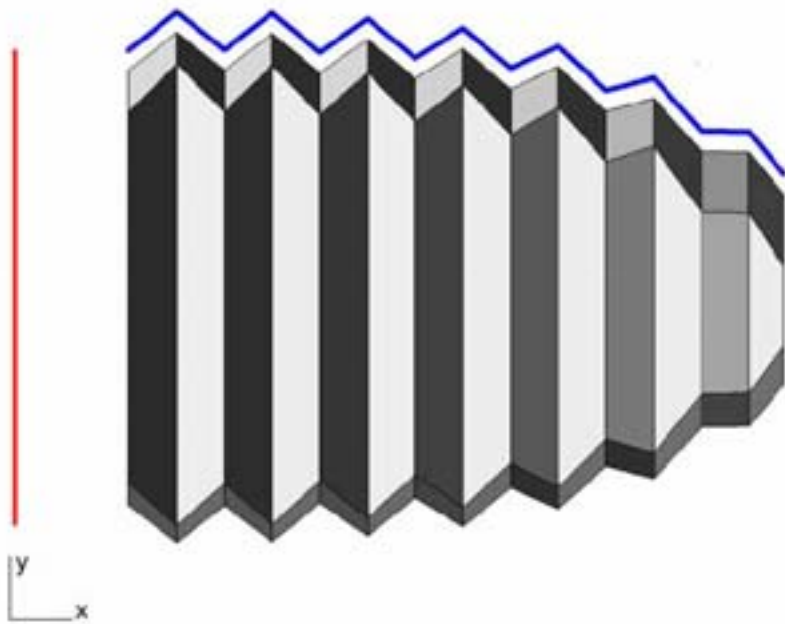

Shel

Hani Buri, Yves Weinand  
Architecture, Engineering and Production Design

Chapel for the deaconesses of St Loup  
Hani Buri  
Tallin, november 2006

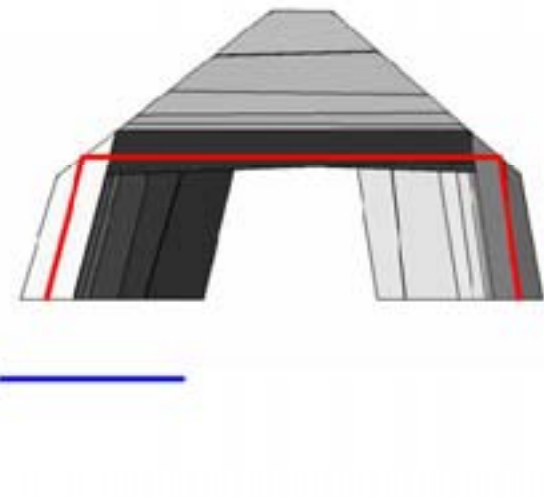
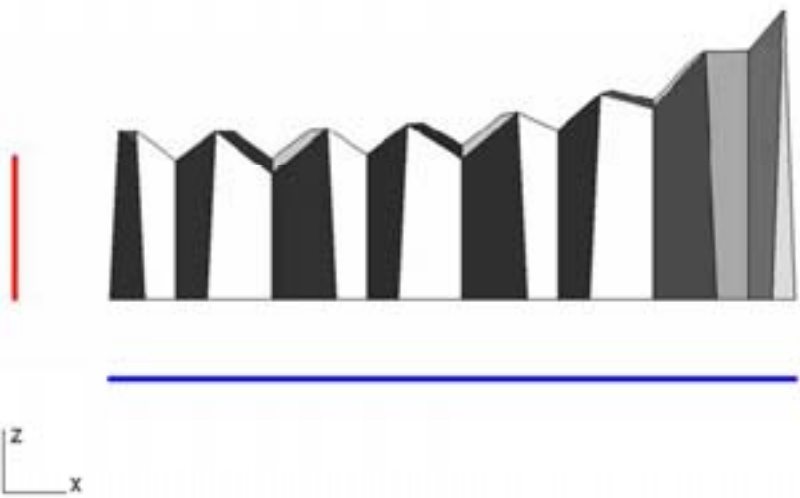
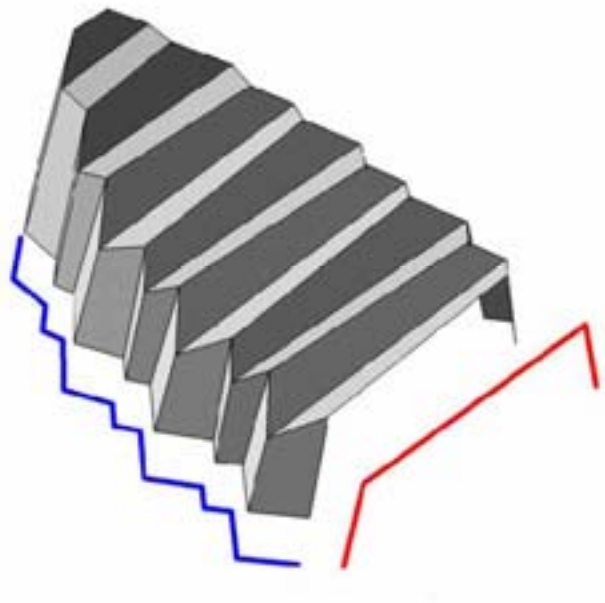
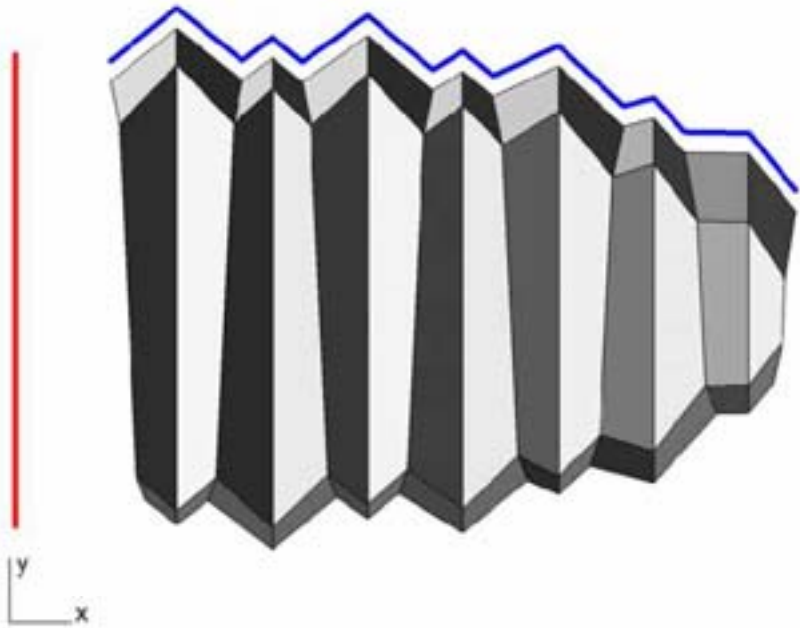

Shel

Hani Buri, Yves Weinand  
Architecture, Engineering and Production Design

*Chapel for the deaconesses of St Loup*  
Hani Buri  
Tallin, november 2006

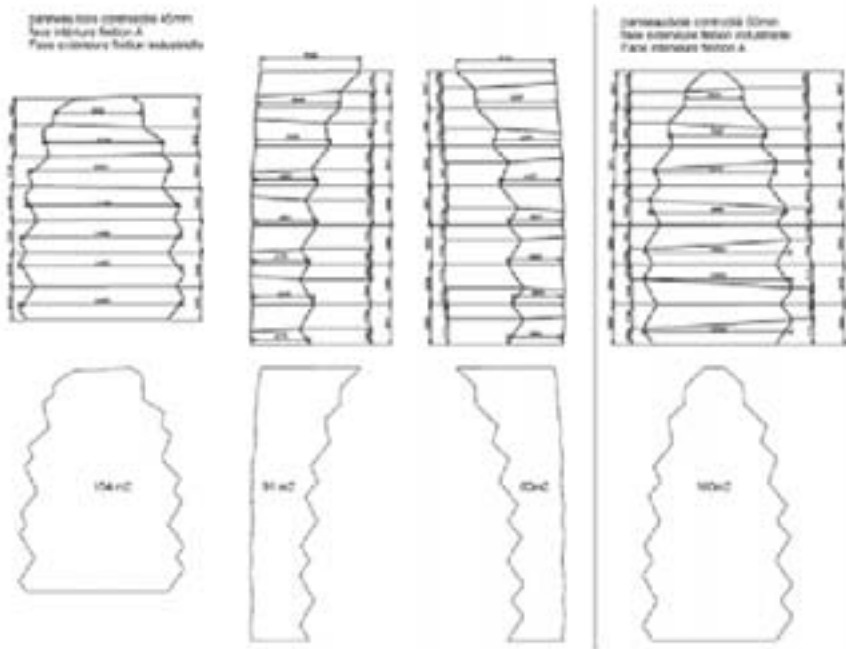
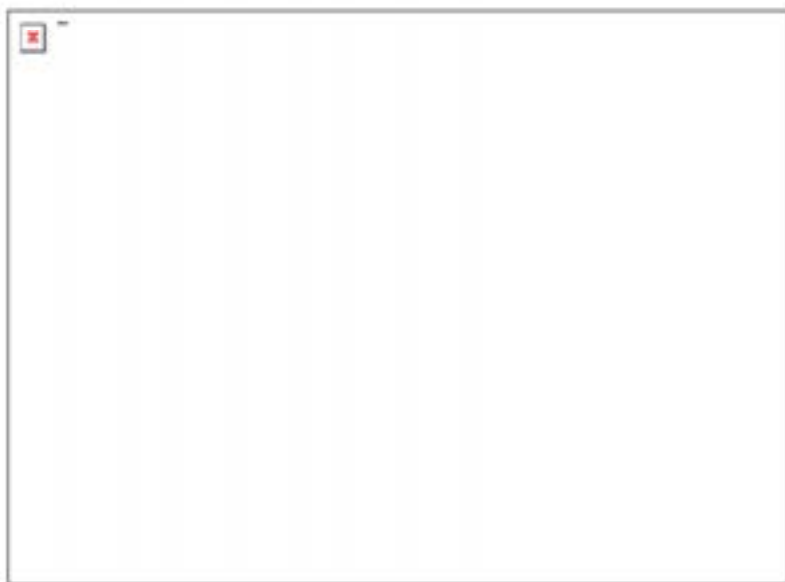

Shel

Hani Buri, Yves Weinand  
 Architecture, Engineering and Production Design

Chapel for the deaconesses of St Loup  
 Hani Buri  
 Tallin, november 2006

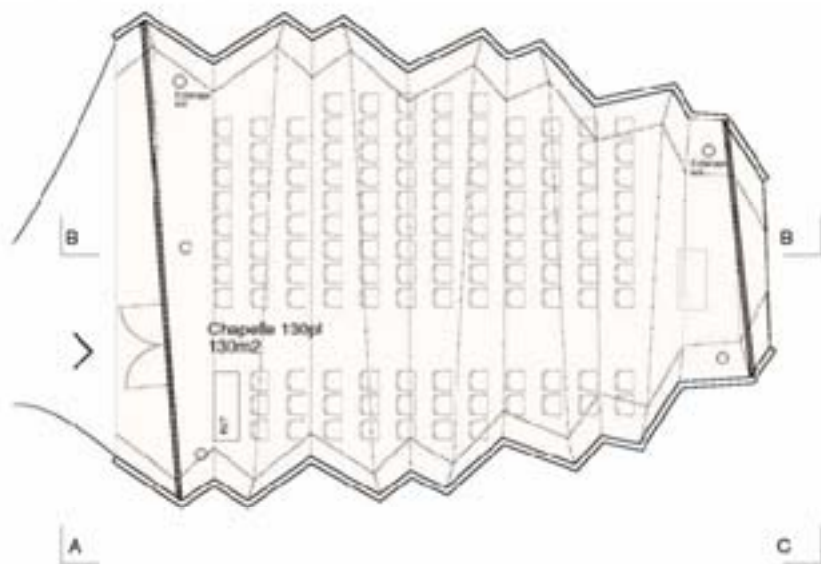

Plan und Schnitt (LOCALARCHITECTURE), Papiermodell (SHEL)

Shel

Hani Buri, Yves Weinand  
Architecture, Engineering and Production Design

*Chapel for the deaconesses of St Loup*  
Hani Buri Tallin, november 2006

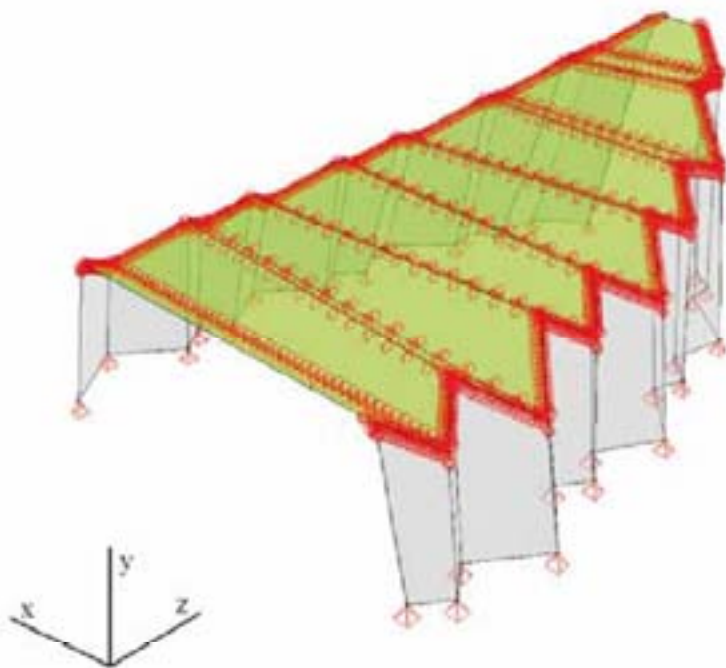

Déformation dy (mm)

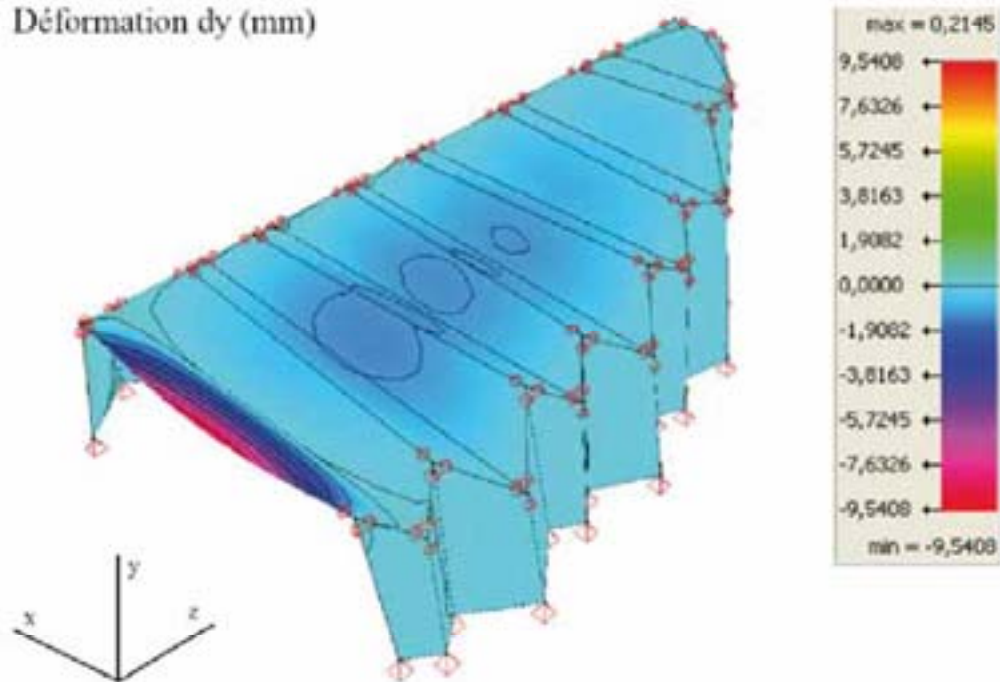

Shel

Hani Buri, Yves Weinand  
Architecture, Engineering and Production Design

*Chapel for the deaconesses of St Loup*  
Hani Buri Tallin, november 2006

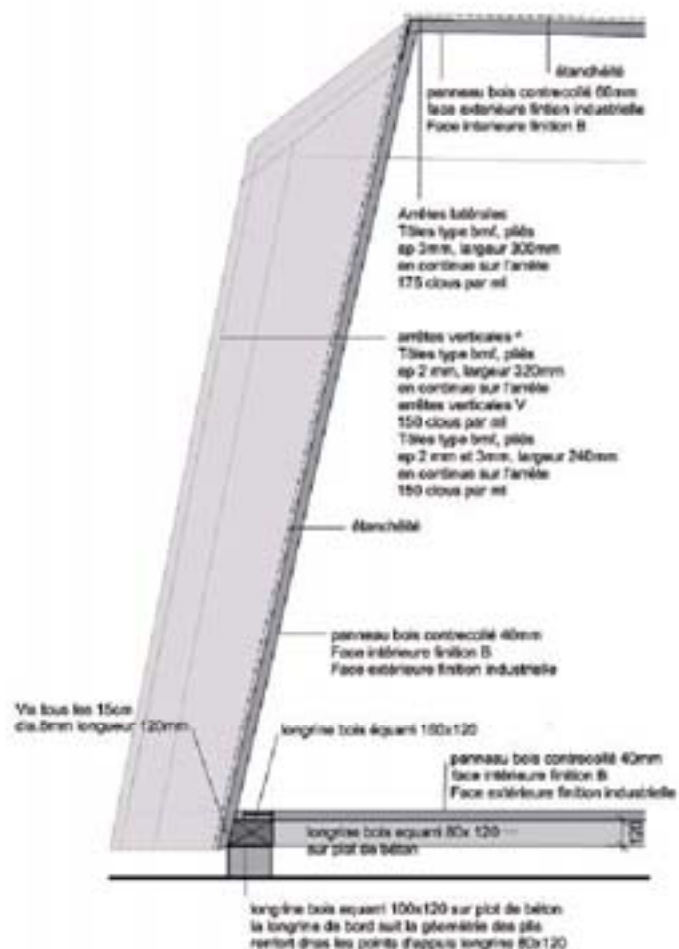

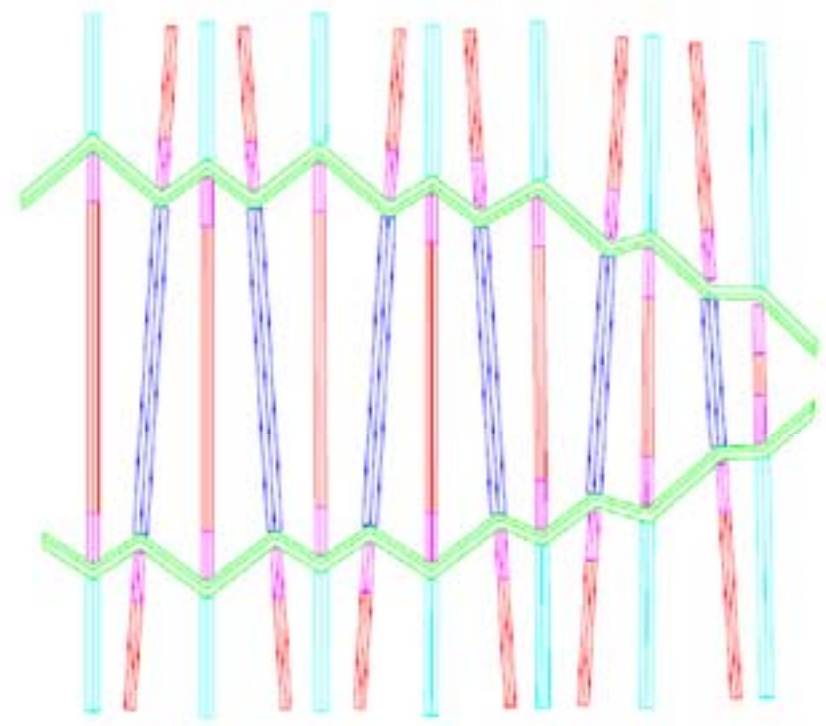
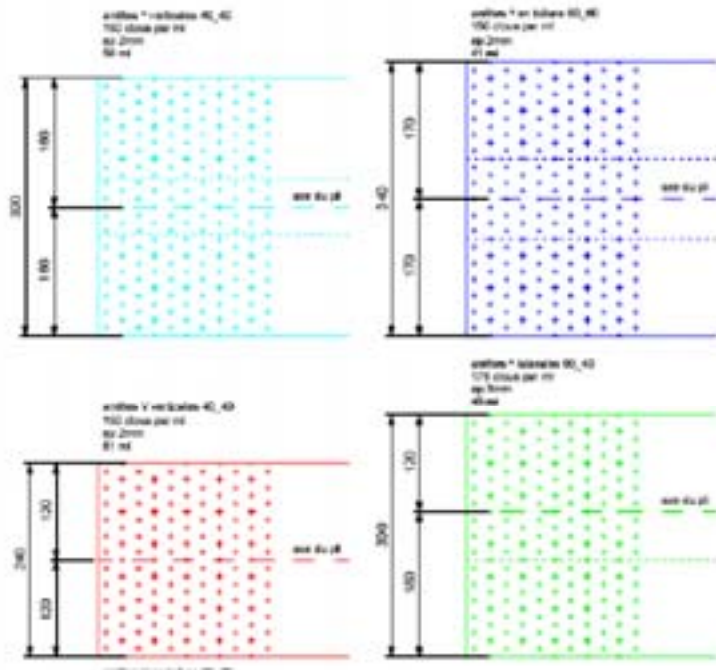

Shel

Hani Buri, Yves Weinand  
 Architecture, Engineering and Production Design

Chapel for the deaconesses of St Loup  
 Hani Buri  
 Tallin, november 2006

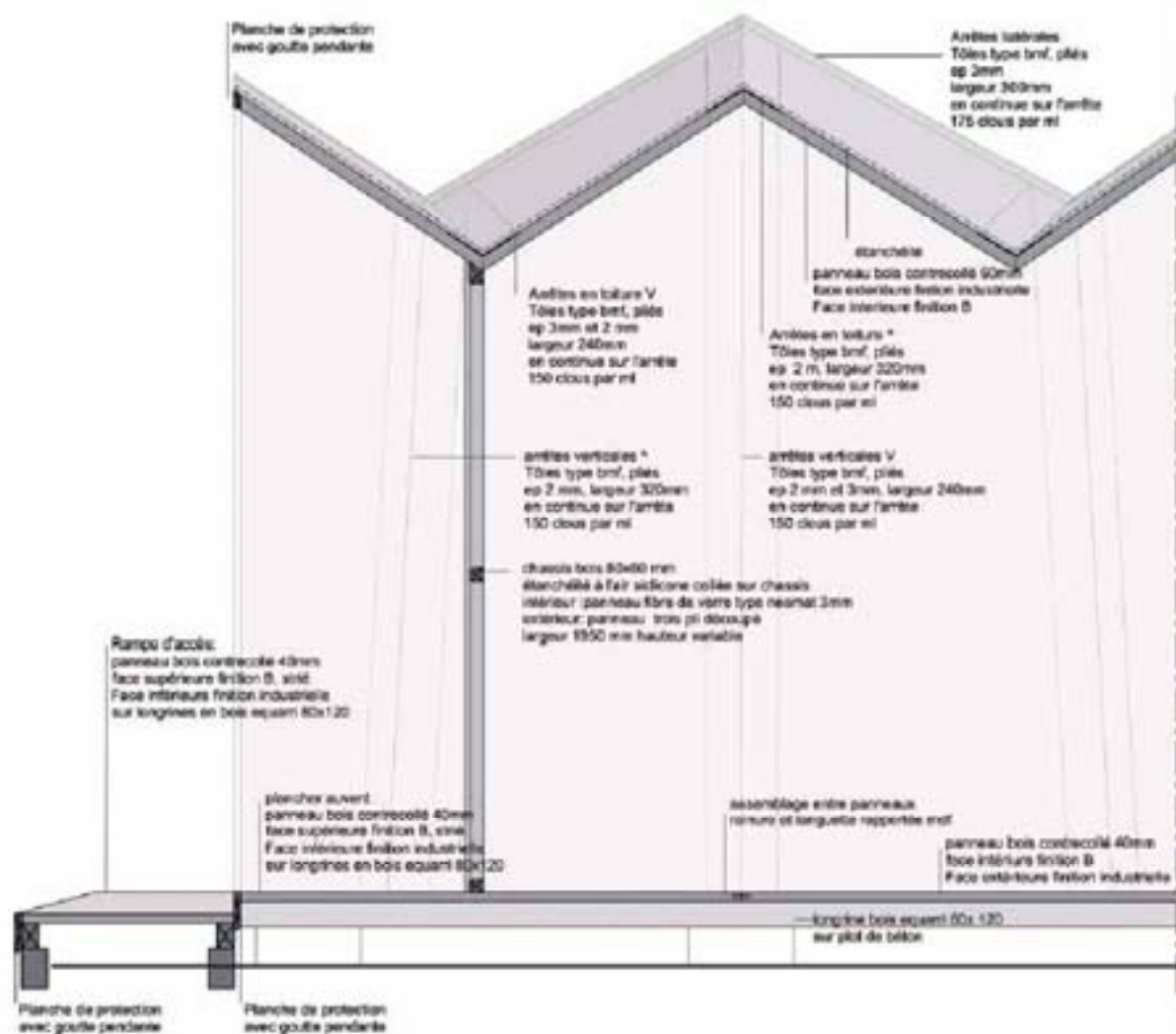



(photo: F.Hatt)

**Shel**

*Hani Buri, Yves Weinand*  
Architecture, Engineering and Production Design

*Chapel for the deaconesses of St Loup*  
Hani Buri *Tallin, november 2006*



(photo: F.Hatt)

**Shel**

*Hani Buri, Yves Weinand*  
Architecture, Engineering and Production Design

*Chapel for the deaconesses of St Loup*  
*Hani Buri* *Tallin, november 2006*



(photo: F.Hatt)

**Shel**

*Hani Buri, Yves Weinand*  
Architecture, Engineering and Production Design

*Chapel for the deaconesses of St Loup*  
*Hani Buri* *Tallin, november 2006*



photo: F.Hatt)

**Shel**

*Hani Buri, Yves Weinand*  
Architecture, Engineering and Production Design

***Chapel for the deaconesses of St Loup***  
*Hani Buri Tallin, november 2006*



(photo: F Hatt)

**Shel** *Hani Buri, Yves Weinand*  
Architecture, Engineering and Production Design

*Chapel for the deaconesses of St Loup*  
*Hani Buri* *Tallin, november 2006*



(photo: F.Hatt)

**Shel**

*Hani Buri, Yves Weinand*  
Architecture, Engineering and Production Design

***Chapel for the deaconesses of St Loup***  
*Hani Buri*      *Tallin, november 2006*



photo: F.Hatt

Shel

*Hani Buri, Yves Weinand*  
Architecture, Engineering and Production Design

*Chapel for the deaconesses of St Loup*  
*Hani Buri* *Tallin, november 2006*

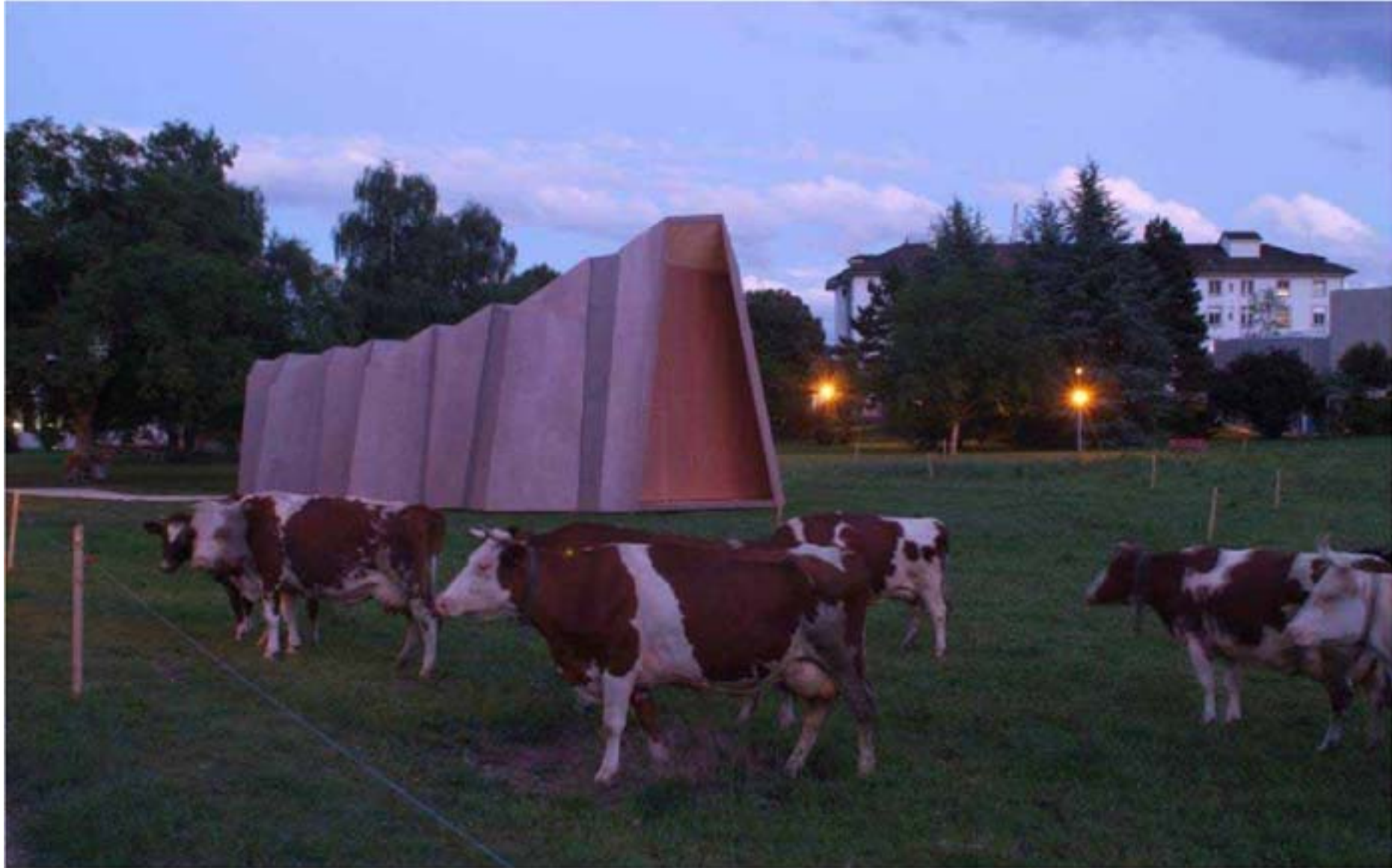

photo: F.Hatt

**Shel**

*Hani Buri, Yves Weinand*  
Architecture, Engineering and Production Design

*Chapel for the deaconesses of St Loup*  
*Hani Buri* *Tallin, november 2006*



(photo: F.Hatt)

**Shel**

*Hani Buri, Yves Weinand*  
Architecture, Engineering and Production Design

***Chapel for the deaconesses of St Loup***  
*Hani Buri Tallin, november 2006*



(photo: F. Hatt)

**Shel**

*Hani Buri, Yves Weinand*  
Architecture, Engineering and Production Design

*Chapel for the deaconesses of St Loup*  
*Hani Buri*      *Tallin, november 2006*



(photo: F Hatt)

**Shel** *Hani Buri, Yves Weinand*  
Architecture, Engineering and Production Design

*Chapel for the deaconesses of St Loup*  
*Hani Buri* *Tallin, november 2006*



(photo: F.Hatt)

# Shel

*Hani Buri, Yves Weinand*  
Architecture, Engineering and Production Design



*Chapel for the deaconesses of St Loup*  
*Hani Buri* *Tallin, november 2006*



(photo: F.Hatt)

**Shel**

*Hani Buri, Yves Weinand*  
Architecture, Engineering and Production Design

***Chapel for the deaconesses of St Loup***  
*Hani Buri*      *Tallin, november 2006*



(photo: F. Hatt)

**Shel** *Hani Buri, Yves Weinand*  
Architecture, Engineering and Production Design

*Chapel for the deaconesses of St Loup*  
*Hani Buri* *Tallin, november 2006*



(photo: F Hatt)



**Shel**

*Hani Buri, Yves Weinand*  
Architecture, Engineering and Production Design

***Chapel for the deaconesses of St Loup***  
*Hani Buri*      *Tallin, november 2006*



(photo: F.Hatt)

**Shel**

*Hani Buri, Yves Weinand*

Architecture, Engineering and Production Design



**Chapel for the deaconesses of St Loup**

*Hani Buri*

*Tallin, november 2006*



(photo: F.Hatt)

**Shel**

*Hani Buri, Yves Weinand*  
Architecture, Engineering and Production Design

***Chapel for the deaconesses of St Loup***  
*Hani Buri*      *Tallin, november 2006*